

FLEXFORM

FLEXFORM | MADE IN ITALY

SEDIE
POLTRONCINE
SGABELLI
TAVOLI
TAVOLINI
CONSOLLE
LIBRERIE
CONTENITORI
COMPLEMENTI
DINING CHAIRS
DINING ARMCHAIRS
BAR STOOLS
TABLES
COFFEE TABLES
SIDE TABLES
CONSOLES
BOOKSHELVES
CABINETS
ACCESSORIES

THE COLLECTION
DINING

Indice prodotti

Product list

Sedie | Poltroncine | Sgabelli

Dining chairs | Dining armchairs | Bar stools

6

ALICE



8

CRONO



12

EVA



16

FEEL GOOD



20

GELSOMINA



30

HERA



34

ISABEL



42

LEDA



48

MIXER



52

MOKA



56

MORGAN



60

ORTIGIA



66

PAT



70

PAUSA



74

Tavoli
Tables

78

CLARKE



80

DIDA



84

FLY



88

GIPSY



94

GUSTAV



98

ISEO



104

JIFF



108

MIXER



112

MOKA



116

MONREALE



120

SOFFIO



124

SPELLO



128

ZEFIRO



132

Tavolini | Consolle

Coffee tables | Side tables | Consoles

140

ASCANIO



142

BRIG



146

CABARÉ



150

CARLOTTA



154

CESTONE



158

CLARKE



162

DIDA



166

ESTE



170

FLY



176

GIANO



184

GIPSY



188

GROUNDPIECE



192

GUSTAV



198

INFINITY



202

JIFF



208

KIDD



212

OLIVER



216

PLAIN



220

SOFFIO



224

SVEVA



230

TINDARI



234

TRIS



238

VIENNA



242

ZEFIRO



246

Librerie | Contenitori | Complementi
Bookshelves | Cabinets | Accessories

250

BOX



252

FLY



254

GROUNDPIECE



258

INFINITY



260

JEREMY



268

LIGHTPIECE



276

MOKA



280

PIUMA



284

TAYLOR



294

Sedie Poltroncine Sgabelli

Dining chairs | Dining armchairs | Bar stools

| | |
|-----------|----|
| ALICE | 8 |
| CRONO | 12 |
| EVA | 16 |
| FEEL GOOD | 20 |
| GELSOMINA | 30 |
| HERA | 34 |
| ISABEL | 42 |
| LEDA | 48 |
| MIXER | 52 |
| MOKA | 56 |
| MORGAN | 60 |
| ORTIGIA | 66 |
| PAT | 70 |
| PAUSA | 74 |



Alice

Design Center 1998

00

**DINING CHAIRS
DINING ARMCHAIRS
BAR STOOLS**



Alice è una poltroncina dalle linee aggraziate e gentili, caratterizzata da uno schienale imbottito morbido ed avvolgente.

Le gambe sono in massello di noce canaletto o frassino e sono proposte in una varietà di tinte che facilitano l'abbinamento con le finiture dei tavoli.

La housse di rivestimento è disponibile nelle varianti corta, che conferisce un aspetto più minimale ed austero alla poltroncina, oppure lunga fino a terra, per una poltroncina che rivela un carattere più decorativo.

A graceful armchair with delicate lines, Alice features a softly-enveloping padded seat back.

The solid Canaletto walnut or ash legs can be stained in many different shades that allow for easy pairing with the Flexform table finishes.

The soft, lightweight upholstery slipcover comes in a short version that lends a more minimal, understated look to the armchair, or floor-length, for an armchair with a more decorative allure.



10



TIPOLOGIE SEDIE/POLTRONCINE/SGABELLI **PRODOTTO** POLTRONCINA **STRUTTURA** IN METALLO CON IMBOTTITURA IN POLIURETANO STAMPATO RIVESTITA IN TESSUTO PROTETTIVO ACCOPPIATO **GAMBE** IN LEGNO MASSELLO DI NOCE CANALETTO NELLE FINITURE NATURALE, TINTO EXTRA, TINTO CAFFÈ O DI FRASSINO NELLE FINITURE NATURALE, TINTO NOCE, TINTO CILIEGIO, TINTO TEAK, TINTO CAFFÈ, TINTO WENGÉ, TINTO EBANO, TINTO MARRONE **RIVESTIMENTO** SFODERABILE SIA NELLA VERSIONE IN TESSUTO CHE NELLA VERSIONE IN PELLE. POSSIBILITÀ DI SCELTA TRA FODERA LUNGA O CORTA

CATEGORIES DINING CHAIRS/DINING ARMCHAIRS/BAR STOOLS **PRODUCT** DINING ARMCHAIR **STRUCTURE** IN METAL WITH MOLDED POLYURETHANE PADDING, COVERED WITH A PROTECTIVE LAMINATED FABRIC **LEGS** IN SOLID CANALETTO WALNUT WITH NATURAL FINISH, OR STAINED CANALETTO WALNUT EXTRA OR COFFEE; OR, IN ASH WITH NATURAL FINISH OR STAINED WALNUT, CHERRY, TEAK, COFFEE, WENGE, EBONY OR BROWN **UPHOLSTERY** IS REMOVABLE IN BOTH THE FABRIC AND LEATHER VERSIONS. CHOICE OF LONG OR SHORT UPHOLSTERED SLIPCOVER

10701

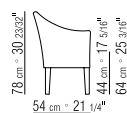
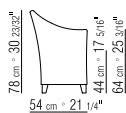

10711

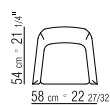
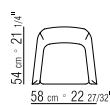

Crono

Antonio Citterio 2016

12



DINING CHAIRS DINING ARMCHAIRS BAR STOOLS

La poltroncina Crono riprende le linee dell'omonima poltrona e mostra proporzioni contenute ed aggraziate. La struttura in legno massello – noce canaletto o frassino tinti in diverse nuance – presenta una lavorazione nella quale si manifesta chiaramente l'attitudine dell'azienda a fare propria l'eredità della tradizione ebanista italiana.

Lo schienale rivela un'originale quanto sofisticata lavorazione con un particolare intreccio eseguito interamente a mano e realizzato con un cordoncino di cuoio, la seduta ha un'imbottitura in poliuretano espanso rivestito in tessuto accoppiato ed il rivestimento – in tessuto o pelle – è sfoderabile.

With its graceful, restrained proportions, the Crono dining armchair reflects the lines of its namesake armchair. The solid wood structure – in Canaletto walnut or ash, stained in various shades – displays the kind of workmanship that clearly expresses the company's flair for embracing the heritage of Italian cabinetmaking tradition as its own.

As unique as it is sophisticated, the seat back is entirely hand-woven in a design made from cowhide cord; the seat is padded with polyurethane foam covered with a laminated fabric, and the upholstery – in fabric or leather – is removable.



14



TIPOLOGIE DIVANI/DIVANI componibili/POUF - POLTRONE/POUF - POLTRONCINE/ SEDIE SGABELLI **PRODOTTO** POLTRONCINA **STRUTTURA** IN LEGNO MASSELLO DI NOCE CANALETTO NELLE FINITURE NATURALE, TINTO EXTRA E TINTO CAFFÈ O MASSELLO DI FRASSINO NELLE FINITURE NATURALE, TINTO NOCE, TINTO CILIEGIO, TINTO TEAK, TINTO CAFFÈ, TINTO WENGÉ, TINTO EBANO, TINTO MARRONE CON CORDONCINO DI CUIO INTRECCIATO NEI COLORI NERO, TESTA DI MORO, TABACCO, NATURALE, OLIVA, GRIGIO, ROSSO BULGARO, TELAIO IN FERRO VERNICIATO A FORNO CON POLVERI EPOSSIDICHE. APPOGGIO A TERRA SU PUNTALI IN MATERIALE TERMOPLASTICO **SEDUTA** IN LEGNO MULTISTRATO E METALLO CON IMBOTTITURA IN POLIURETANO ESPANSO RIVESTITA IN TESSUTO PROTETTIVO ACCOPPIATO **CUSCINO SCHIENALE** IN PIUMA D'OCA STERILIZZATA (CERTIFICATA ASSOPIUMA, ETICHETTA ORO). IL CUSCINO SCHIENALE È A RICHIESTA CON SUPPLEMENTO DI PREZZO. **RIVESTIMENTO** SFODERABILE SIA NELLA VERSIONE IN TESSUTO CHE NELLA VERSIONE IN PELLE

CATEGORIES SOFAS/SECTIONAL SOFAS/OTTOMAN - ARMCHAIRS/OTTOMANS - DINING CHAIRS/DINING ARMCHAIRS/BAR STOOLS **PRODUCT** DINING ARMCHAIR **STRUCTURE** IN SOLID CANALETTO WALNUT WITH NATURAL FINISH OR STAINED CANALETTO WALNUT EXTRA OR COFFEE; OR, IN SOLID ASH WITH NATURAL FINISH OR STAINED WALNUT, CHERRY, TEAK, COFFEE, WENGE, EBONY OR BROWN, WITH WOVEN COWHIDE CORD IN BLACK, DARK BROWN, TOBACCO, NATURAL, OLIVE, GREY OR BULGARIAN RED; EPOXY POWDER-COATED METAL FRAME. RESTS ON PADS MADE OF THERMOPLASTIC MATERIAL **SEAT** IN PLYWOOD AND METAL WITH POLYURETHANE FOAM PADDING, COVERED WITH A PROTECTIVE LAMINATED FABRIC **BACKREST CUSHION** IN STERILIZED GOOSE DOWN (ASSOPIUMA CERTIFIED, GOLD LABEL) THE BACKREST CUSHION IS OPTIONAL, UPON REQUEST, WITH UPCHARGE **UPHOLSTERY** IS REMOVABLE IN BOTH THE FABRIC AND LEATHER VERSIONS

22021/22031

22096

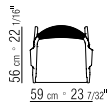
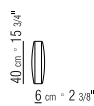
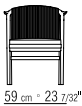
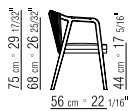

Crono

Data Sheet

Eva

Paolo Nava 1983

16

**DINING CHAIRS
DINING ARMCHAIRS
BAR STOOLS**



Sottile, longilinea, decisamente femminile, Eva si inserisce a buon titolo nel solco della tradizione della sedia habillée.

L'esile struttura in metallo è imbottita in poliuretano espanso rivestito in tessuto protettivo accoppiato a garantire un ottimo livello di confort.

La housse di rivestimento è prevista in due versioni: taglio "sari" dal carattere più asciutto ed essenziale oppure taglio "chemisier", con un raffinato sfondo piega chiuso da bottoni che contraddistingue la parte posteriore della seduta e conferisce alla sedia Eva un appeal decisamente più decorativo.

Raffinato anche l'appoggio a terra a mezzo di un prezioso puntale in ottone.

Slender, long-limbed, distinctly feminine, Eva justifiably joins the ranks of the traditional chaise habillée (dressed chair).

The slim metal structure is wrapped in polyurethane foam and covered with a protective laminated fabric to ensure the utmost comfort.

The soft, lightweight upholstery slipcover comes in two versions: the "sari", with leaner, more minimal lines, or the "chemisier", with an elegant back pleat and button closure that dresses up the back of the dining chair and lends Eva an unmistakably decorative look.

The feet are 'dressed' too, with brass tips that add another layer of refined elegance.





TIPOLOGIE SEDIE/POLTRONCINE/SGABELLI **PRODOTTO** SEDIA **STRUTTURA** IN METALLO CON IMBOTTITURA IN POLIURETANO ESPANSO RIVESTITA IN TESSUTO PROTETTIVO ACCOPPIATO **GAMBE** IN METALLO CON PUNTALE IN OTTONE. APPOGGIO A TERRA SU PUNTALI IN MATERIALE TERMOPLASTICO **RIVESTIMENTO** SFODERABILE SIA NELLA VERSIONE IN TESSUTO CHE NELLA VERSIONE IN PELLE. LE FODERE POSSONO ESSERE CONFEZIONATE NELLE VERSIONI CON TAGLIO "SARI" O "CHEMISIER"

CATEGORIES DINING CHAIRS/DINING ARMCHAIRS/BAR STOOLS **PRODUCT** DINING CHAIR **STRUCTURE** IN METAL WITH POLYURETHANE FOAM PADDING, COVERED WITH A PROTECTIVE LAMINATED FABRIC **LEGS** IN METAL WITH BRASS TIP. RESTS ON PADS MADE OF THERMOPLASTIC MATERIAL **UPHOLSTERY** IS REMOVABLE IN BOTH THE FABRIC AND LEATHER VERSIONS. THE SLIPCOVERS ARE AVAILABLE IN "SARI" OR "CHEMISIER" VERSIONS

11801

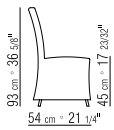

11821

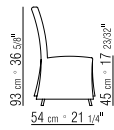

Eva
Data Sheet

Feel Good

Antonio Citterio 2013

20



**DINING CHAIRS
DINING ARMCHAIRS
BAR STOOLS**

Feel Good è un'ampia famiglia di sedute, che comprende anche sedie, poltroncine e sgabelli ed è contraddistinta da una grande versatilità: intramontabile per la classicità del disegno e contemporanea nelle forme.

A caratterizzare le sedie Feel Good sono le slanciate gambe in alluminio, realizzate su disegno esclusivo e disponibili nelle finiture satinato, cromato, brunito, cromo nero e champagne.

È disponibile anche la versione con gambe in massello di noce canaletto e frassino, proposti in una varietà di tinte.

La scocca caratterizzata da una forma avvolgente è in poliuretano strutturale e poliuretano espanso mentre i cuscini di seduta sono generosamente imbottiti, per garantire un elevato livello di confort.

Feel Good is an extremely versatile and vast range of seating options that also includes dining chairs, dining armchairs and bar stools, well-known for their timeless classic design and contemporary lines.

Feel Good chairs are distinguished by their sleek aluminum legs, based on an exclusive Flexform design, and available in satin, chrome, burnished, black chrome or champagne finish.

They also come in a version with solid Canaletto walnut or ash legs, available in a number of stain finishes.

The chair's shell, with its enveloping shape, is made of structural polyurethane and polyurethane foam while the seat cushions are generously padded to ensure maximum comfort.







To ensure ergonomics and maximum comfort, the enveloping shell of the backrest and the seat are generously padded.





BELGIUM | KNOKKE | PRIVATE RESIDENCE | FEEL GOOD BAR STOOLS





TIPOLOGIE DIVANI/DIVANI COMPONENTI/POUF - POLTRONE/POUF - CHAISELONGUE DORMEUSE - SEDIE/POLTRONCINE/SGABELLI **PRODOTTO** POLTRONCINA - SEDIA - SGABELLO **STRUTTURA** IN POLIURETANO RIGIDO E POLIURETANO ESPANSO **CUSCINO SEDUTA** IN PIUMA D'OCA STERILIZZATA (CERTIFICATA ASSOPIUMA, ETICHETTA ORO) PER POLTRONA E POUF; IN POLIURETANO ESPANSO E DACRON PER SGABELLO, POLTRONCINA DA PRANZO E SEDIA **GAMBE** IN METALLO NELLE FINITURE SATINATO, CROMATO, CROMO NERO, BRUNITO, CHAMPAGNE O IN LEGNO MASSELLO DI NOCE CANALETTO NELLE FINITURE NATURALE, TINTO EXTRA, TINTO CAFFÈ O DI FRASSINO NELLE FINITURE NATURALE, TINTO NOCE, TINTO CILIEGIO, TINTO TEAK, TINTO CAFFÈ, TINTO WENGÉ, TINTO EBANO, TINTO MARRONE. APPOGGIO A TERRA SU PUNTALI IN MATERIALE TERMOPLASTICO **RIVESTIMENTO** NON SFODERABILE SIA NELLA VERSIONE IN TESSUTO CHE NELLA VERSIONE IN PELLE. LA SCELTA DEL TESSUTO È DA EFFETTUARSI PREVIA VERIFICA DELLA POSSIBILITÀ DI UTILIZZO

CATEGORIES SOFAS/SECTIONAL SOFAS/OTTOMANS - ARMCHAIRS/OTTOMANS - CHAISE LONGUES/DORMEUSE - DINING CHAIRS/DINING ARMCHAIRS/BAR STOOLS **PRODUCT** DINING ARMCHAIR - DINING CHAIR - BAR STOOL **STRUCTURE** IN RIGID POLYURETHANE AND POLYURETHANE FOAM **SEAT CUSHION** IN STERILIZED GOOSE DOWN (ASSOPIUMA CERTIFIED, GOLD LABEL) FOR THE ARMCHAIR AND OTTOMAN; IN POLYURETHANE FOAM AND DACRON FOR THE FOOTSTOOL, DINING CHAIR AND CHAIR **LEGS** IN METAL WITH SATIN, CHROME, BLACK CHROME, BURNISHED OR CHAMPAGNE FINISH; OR, IN SOLID CANALETTO WALNUT WITH NATURAL FINISH, OR STAINED CANALETTO WALNUT EXTRA OR COFFEE; OR, IN ASH WITH NATURAL FINISH OR STAINED WALNUT, CHERRY, TEAK, COFFEE, WENGE, EBONY OR BROWN. RESTS ON PADS MADE OF THERMOPLASTIC MATERIAL **UPHOLSTERY** IS NON-REMOVABLE IN BOTH THE FABRIC AND LEATHER VERSIONS. FABRIC CHOICE MUST BE APPROVED IN ADVANCE BEFORE ORDER CAN BE PLACED

14WA1



14WA2

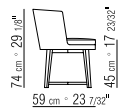

14WA5



14WA6



14WA3

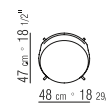
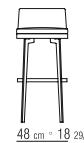
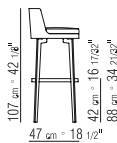

14WA4

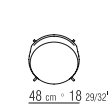
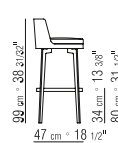

14WA7

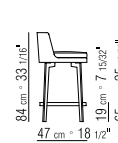

Gelsomina

Antonio Citterio 2010

30



**DINING CHAIRS
DINING ARMCHAIRS
BAR STOOLS**

Delicata e gentile, la sedia Gelsomina presenta linee curve e femminili. La struttura è in massello di noce canaletto o frassino, in una varietà di tinte che rendono la sedia Gelsomina particolarmente versatile. L'appoggio all'essenziale schienale in legno di forma semicircolare è reso più confortevole da un morbido cuscino in piuma d'oca. Gelsomina ha una personalità camaleontica. La purezza del disegno consegna alla scelta dell'essenza e del tessuto o pelle di rivestimento la connotazione stilistica finale della sedia.

The sleek, refined Gelsomina chair is gracefully curved and feminine. The structure is made of solid Canaletto walnut or ash, available in an array of stains that make the Gelsomina chair especially versatile. A soft goose-down cushion lends luxurious comfort to the spare semi-circular wood seat back. Gelsomina has a chameleon-like personality. Its purity of design allows the stylistic signature of the chair to be determined by the type of wood and the fabric or leather upholstery selected.



32



The purity of design and the graceful lines of the Gelsomina chair make it very versatile and suitable for any setting.

TIPOLOGIE SEDIE/POLTRONCINE/SGABELLI **PRODOTTO** POLTRONCINA **STRUTTURA E SCHIENALE** IN LEGNO MASSELLO DI NOCE CANALETTO NELLE FINITURE NATURALE, TINTO EXTRA, TINTO CAFFÈ O MASSELLO DI FRASSINO NELLE FINITURE NATURALE, TINTO NOCE, TINTO CILIEGIO, TINTO TEAK, TINTO CAFFÈ, TINTO WENGÉ, TINTO EBANO, TINTO MARRONE. APOGGIO A TERRA SU PUNTALI IN MATERIALE TERMOPLASTICO **SEDUTA** IN LEGNO MULTISTRATO CON IMBOTTITURA IN POLIURETANO ESPANSO RIVESTITA IN TESSUTO PROTETTIVO ACCOPPIATO **CUSCINO SCHIENALE** IN PIUMA D'OCA STERILIZZATA (CERTIFICATA ASSOPIUMA, ETICHETTA ORO). IL CUSCINO SCHIENALE È A RICHIESTA CON SUPPLEMENTO DI PREZZO **RIVESTIMENTO** SFODERABILE SIA NELLA VERSIONE IN TESSUTO CHE NELLA VERSIONE IN PELLE

CATEGORIES DINING CHAIRS/DINING ARMCHAIRS/BAR STOOLS **PRODUCT** DINING ARMCHAIR **STRUCTURE AND BACKREST** IN SOLID CANALETTO WALNUT WITH NATURAL FINISH OR STAINED CANALETTO WALNUT EXTRA OR COFFEE; OR, IN SOLID ASH WITH NATURAL FINISH OR STAINED WALNUT, CHERRY, TEAK, COFFEE, WENGE, EBONY OR BROWN. RESTS ON PADS MADE OF THERMOPLASTIC MATERIAL **SEAT** IN PLYWOOD WITH POLYURETHANE FOAM PADDING, COVERED WITH A PROTECTIVE LAMINATED FABRIC **BACKREST CUSHION** IN STERILIZED GOOSE DOWN (ASSOPIUMA CERTIFIED, GOLD LABEL) THE BACKREST CUSHION IS OPTIONAL, UPON REQUEST, WITH UPCHARGE **UPHOLSTERY** IS REMOVABLE IN BOTH THE FABRIC AND LEATHER VERSIONS

15H21

15H99

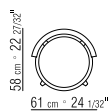
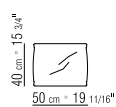

Gelsomina

Data Sheet

Hera

Antonio Citterio 2018

34



**DINING CHAIRS
DINING ARMCHAIRS
BAR STOOLS**

Hera è una famiglia di poltrone e sedie, che esprime una felice sintesi di ergonomia ed eleganza, espressamente progettata sia per un utilizzo in ambito domestico che per contesti hospitality, quali aree lounge, sale d'attesa, ristoranti.

Presenta una costruzione leggera grazie alla scocca realizzata in uno speciale materiale polimerico, che garantisce un elevato livello di confort.

Le poltrone e le sedie Hera sono completamente sfoderabili e sono proposte nella duplice versione con affusolate gambe in alluminio pressofuso nelle finiture satinato, cromato, brunito, cromato nero e champagne oppure in massello di noce canaletto o di frassino in una varietà di tinte.

Hera is a family of dining armchairs and chairs that brilliantly combines ergonomics and elegance, specifically designed for use both in domestic and hospitality settings like lounges, waiting rooms and restaurants.

Thanks to a shell made of a special polymer, its construction is graceful and ensures premium comfort.

The Hera dining armchairs and dining chairs have completely removable upholstery and are available in two versions: with tapered, cast aluminum legs with satin, chromed, burnished, black chromed or champagne finish; as well as in solid Canaletto walnut or solid ash stained in a choice of shades.











TIPOLOGIE SEDIE/POLTRONCINE/SGABELLI **PRODOTTO** SEDIA - POLTRONCINA
STRUTTURA IMBOTTITA IN MATERIALE BREVETTATO COMPRENDENTI VARIE
COMBINAZIONI DI SKIN E CORE **GAMBE** IN LEGNO MASSELLO DI NOCE CANALETTO
NELLE FINITURE NATURALE, TINTO EXTRA, TINTO CAFFÈ O MASSELLO DI FRASSINO
NELLE FINITURE NATURALE, TINTO NOCE, TINTO CILIEGIO, TINTO TEAK, TINTO CAFFÈ,
TINTO WENGÉ, TINTO EBANO, TINTO MARRONE O IN METALLO NELLE FINITURE
SATINATO, CROMATO, CROMO NERO, BRUNITO, CHAMPAGNE. APPOGGIO A TERRA
SU PUNTALI IN MATERIALE TERMOPLASTICO **RIVESTIMENTO** SFODERABILE SIA
NELLA VERSIONE IN TESSUTO CHE NELLA VERSIONE IN PELLE

CATEGORIES DINING CHAIRS/DINING ARMCHAIRS/BAR STOOLS **PRODUCT** DINING
CHAIR - DINING ARMCHAIR **STRUCTURE** PADDED WITH PATENTED MATERIAL **LEGS**
IN SOLID CANALETTO WALNUT WITH NATURAL FINISH, OR STAINED CANALETTO
WALNUT EXTRA OR COFFEE; OR, IN SOLID ASH WITH NATURAL FINISH OR STAINED
WALNUT, CHERRY, TEAK, COFFEE, WENGE, EBONY OR BROWN; OR, IN METAL WITH
SATIN, CHROME, BLACK CHROME, BURNISHED OR CHAMPAGNE FINISH. RESTS ON
PADS MADE OF THERMOPLASTIC MATERIAL **UPHOLSTERY** IS REMOVABLE IN BOTH
THE FABRIC AND LEATHER VERSIONS

24601/24603

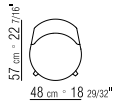

246A1/246A3

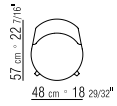

24602

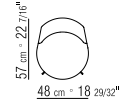
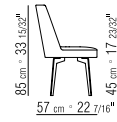

246A2

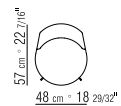
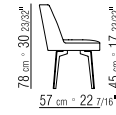

24611/24613

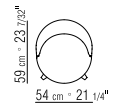

24612

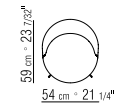
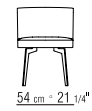
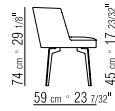

246B1/246B3

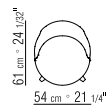
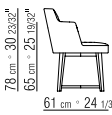

246B2

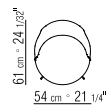
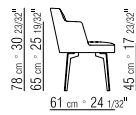

Isabel

Carlo Colombo 2014 | 2018

42

DINING CHAIRS DINING ARMCHAIRS BAR STOOLS



Una famiglia di sedie, poltroncine e sgabelli nella quale il progetto è dettato dall'intrinseca espressività di un materiale nobile e versatile come il cuoio.

Ricca nei contenuti e nella confezione, la sedia Isabel presenta una linea asciutta ed essenziale.

È interamente rivestita in cuoio, gambe incluse, ed è caratterizzata da uno schienale avvolgente ed estremamente confortevole.

Nella poltroncina, lo schienale rivestito in cuoio si prolunga nei braccioli i quali, aprendosi lievemente alle estremità, creano una leggera piega nel cuoio, che ricorda l'arte giapponese dell'origami.

Grazie alla sua linea ricercata, la sedia, la poltroncina e lo sgabello Isabel si inseriscono armoniosamente sia in contesti residenziali che in progetti hospitality.

The design project for this family of dining chairs, dining armchairs and bar stools was dictated by the inherent eloquence of a handsomely versatile natural material like cowhide.

Dense with content and expertly crafted, the Isabel dining chair's lines are clean and uncluttered.

Entirely clad in cowhide, including the legs, the dining chair features a gently-enveloping and extremely comfortable seat back.

The cowhide-clad seat back of the dining armchair extends into the armrests which, by opening out slightly at the ends, create a delicate fold in the cowhide, reminiscent of the Japanese art of origami.

With their sophisticated lines, the Isabel dining chair, dining armchair and bar stool are perfectly at home in both residential interiors and hospitality projects.









TIPOLOGIE SEDIE/POLTRONCINE/SGABELLI **PRODOTTO** SEDIA - POLTRONCINA - SGABELLO **STRUTTURA** IN METALLO VERNICIATA A FORNO CON POLVERI EPOSSIDICHE, LEGNO MULTISTRATO E POLIURETANO ESPANSO. APPOGGIO A TERRA SU PUNTALI IN MATERIALE TERMOPLASTICO **RIVESTIMENTO** SFODERABILE IN CUOIO NEI COLORI BIANCO 5007, GRIGIO 5003, TESTA DI MORO 5004, TESTA DI MORO SCURO 5013, NERO 5005, OLIVA 5006, ROSSO BULGARO 5008, SABBIA 5001, TABACCO 5015

CATEGORIES DINING CHAIRS/DINING ARMCHAIRS/BAR STOOLS **PRODUCT** DINING CHAIR - DINING ARMCHAIR - BAR STOOL **STRUCTURE** IN EPOXY POWDER-COATED METAL, PLYWOOD AND POLYURETHANE FOAM. RESTS ON PADS MADE OF THERMOPLASTIC MATERIAL **UPHOLSTERY** REMOVABLE IN COWHIDE IN THE FOLLOWING COLORS: WHITE 5007, GREY 5003, DARK BROWN 5004, EXTRA DARK BROWN 5013, BLACK 5005, OLIVE 5006, BULGARIAN RED 5008, SAND 5001, TOBACCO 5015

20301

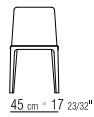

20311

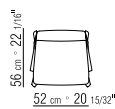

20350

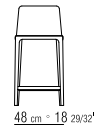
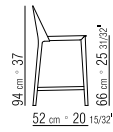

Isabel

Data Sheet

Leda

Antonio Citterio 2018

48

**DINING CHAIRS
DINING ARMCHAIRS
BAR STOOLS**



Una famiglia di sedute in perfetto equilibrio tra tradizione e modernità, che rappresenta in modo esemplare come la produzione seriale dell'azienda conservi un legame profondo con l'artigianalità.

Motivo caratterizzante è la base in legno che richiama la tradizione del design scandinavo e coniuga eleganza e razionalità. Su di essa si innesta il morbido guscio imbottito della seduta. La scocca dalla forma avvolgente è realizzata in uno speciale materiale polimerico dalle ottime proprietà strutturali, che conferisce morbidezza per garantire il massimo confort.

La famiglia Leda comprende due poltrone, una con schienale basso e una con schienale alto ed inoltre una sedia ed una poltroncina.

Tutti gli elementi della famiglia Leda sono completamente sfoderabili.

Exemplary of how the company, in an age of standardized production, maintains its deep ties with artisan craftsmanship is this family of dining chairs neatly balanced between tradition and modernity.

The wood base is distinguished by a motif that echoes the tradition of Scandinavian design with a blend of elegance and rationality. Grafted into the base is the soft, padded shell of the seat. This enveloping shell is made of a special polymer that offers superior structural properties and the kind of softness that ensures the utmost in comfort.

The Leda family includes two armchairs – with low seat back or high seat back – along with a dining chair and a dining armchair.

The upholstery is removable on all of the pieces in the Leda family.



50

Neatly balanced between tradition and modernity, the Leda chair shows how the Company maintains its deep ties with artisan craftsmanship.



TIPOLOGIE SEDIE/POLTRONCINE/SGABELLI **PRODOTTO** SEDIA/POLTRONCINA
STRUTTURA IMBOTTITA IN MATERIALE BREVETTATO COMPRENDENTI VARIE
 COMBINAZIONI DI SKIN E CORE **GAMBE** IN LEGNO MASSELLO DI NOCE CANALETTO
 NELLE FINITURE NATURALE, TINTO EXTRA, TINTO CAFFÈ O MASSELLO DI FRASSINO
 NELLE FINITURE NATURALE, TINTO NOCE, TINTO CILIEGIO, TINTO TEAK, TINTO
 CAFFÈ, TINTO WENGÉ, TINTO EBANO, TINTO MARRONE **GAMBE COD. 24703/24713**
 DISPONIBILI ANCHE IN ALLUMINIO PRESSOFUSO NELLE FINITURE SATINATO,
 CROMATO, CROMO NERO, BRUNITO, CHAMPAGNE. APPOGGIO A TERRA SU PUNTALI
 IN MATERIALE TERMOPLASTICO **RIVESTIMENTO** SFODERABILE SIA NELLA VERSIONE
 IN TESSUTO CHE NELLA VERSIONE IN PELLE

CATEGORIES DINING ARMCHAIRS/DINING CHAIRS/BAR STOOLS **PRODUCT** DINING
 ARMCHAIR/DINING CHAIR **STRUCTURE** PADDED WITH PATENTED MATERIAL **LEGS** IN
 SOLID CANALETTO WALNUT WITH NATURAL FINISH, OR STAINED CANALETTO WALNUT
 EXTRA OR COFFEE; OR, IN SOLID ASH WITH NATURAL FINISH OR STAINED WALNUT,
 CHERRY, TEAK, COFFEE, WENGE, EBONY OR BROWN **LEGS COD. 24703/24713** ALSO
 AVAILABLE IN CAST ALUMINUM WITH SATIN, CHROME, BLACK CHROME, BURNISHED
 OR CHAMPAGNE FINISH RESTS ON PADS MADE OF THERMOPLASTIC MATERIAL
UPHOLSTERY IS REMOVABLE IN BOTH THE FABRIC AND LEATHER VERSIONS

24701/24702

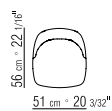
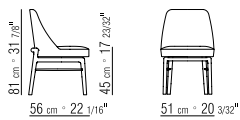

24703

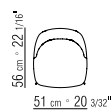
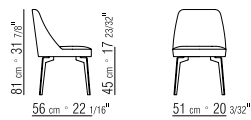

24711/24712

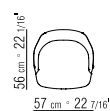
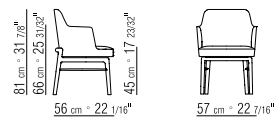

24713

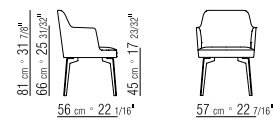

Leda
 Data Sheet

Mixer

Design Center 1985

52

DINING CHAIRS DINING ARMCHAIRS BAR STOOLS



La poltroncina Mixer è un prodotto connotato da una grande concretezza progettuale, polivalente in termini di utilizzo. Grazie alle sue caratteristiche costruttive e alle proporzioni compatte, la poltroncina Mixer si presta ad essere inserita sia in ambienti domestici, sia in uffici e in sale riunioni.

La struttura di forma semicircolare è in metallo e poliuretano integrale, le gambe in metallo sono proposte nelle versioni satinato, alluminio o verniciate in colore nero. La versione con ruote pivotanti rende la poltroncina Mixer ancora più agile e funzionale.

La housse di rivestimento, di facile rimozione sia nella versione in tessuto che in pelle, è proposta nelle varianti lunga e corta.

The Mixer dining armchair is a product with very down-to-earth design bones and the kind of versatility that can be put to many uses. Thanks to its construction features and compact proportions, the Mixer dining armchair is the ideal decor solution for the home or for offices and conference rooms.

The semi-circular structure is made of metal and integral skin polyurethane foam. The metal legs come in satin finish or painted black or aluminum color. A version with spinner wheels makes Mixer even more fleet-footed and functional.

The slipcover, in either fabric or leather, is easy to remove and comes in both long and short versions.



54



TIPOLOGIE SEDIE/POLTRONCINE/SGABELLI - TAVOLI **PRODOTTO** POLTRONCINA **STRUTTURA** IN METALLO E POLIURETANO INTEGRALE **SEDUTA** IN LEGNO MULTISTRATO CON IMBOTTITURA IN POLIURETANO STAMPATO RIVESTITA IN TESSUTO PROTETTIVO ACCOPPIATO **GAMBE** IN METALLO NELLE FINITURE NERO, ALLUMINIO, SATINATA. DISPONIBILE NELLE VERSIONI CON O SENZA RUOTE IN METALLO E GOMMA **RIVESTIMENTO** SFODERABILE SIA NELLA VERSIONE IN TESSUTO CHE NELLA VERSIONE IN PELLE. DISPONIBILE NELLE VERSIONI CON FODERA LUNGA O CORTA

CATEGORIES DINING CHAIRS/DINING ARMCHAIRS/BAR STOOLS - TABLES **PRODUCT** DINING ARMCHAIR **STRUCTURE** IN METAL AND INTEGRAL SKIN POLYURETHANE FOAM **SEAT** IN PLYWOOD WITH MOLDED POLYURETHANE FOAM PADDING, COVERED WITH A PROTECTIVE LAMINATED FABRIC **LEGS** IN METAL WITH BLACK, ALUMINUM OR SATIN FINISH. AVAILABLE WITH OR WITHOUT SPINNER WHEELS IN METAL AND RUBBER **UPHOLSTERY** IS REMOVABLE IN BOTH THE FABRIC AND LEATHER VERSIONS. AVAILABLE WITH LONG OR SHORT SLIPCOVER

13001

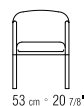
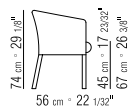

13021

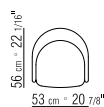
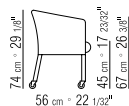

13041

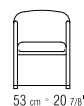
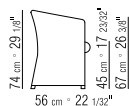

13061

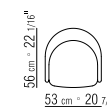
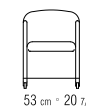
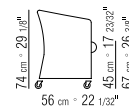

Mixer

Data Sheet

Moka

Mario Asnago | Claudio Vender 1985

56

**DINING CHAIRS
DINING ARMCHAIRS
BAR STOOLS**



Progettata nel 1939 da Mario Asnago e Claudio Vender, la sedia Moka fa parte della collezione Flexform dal 1985. Mario Asnago e Claudio Vender iniziano il loro sodalizio professionale negli anni Trenta del Novecento e sono a buon titolo considerati tra i maggiori esponenti del razionalismo italiano.

La sedia Moka presenta una sorprendente modernità ed è ricca di riferimenti e di echi progettuali che rimandano al razionalismo più puro. La struttura della sedia è costituita da un esile quanto elegante tubolare metallico disponibile nelle finiture verniciato alluminio, bianco e nero. Lo schienale è caratterizzato da un raffinato incrocio e la seduta è realizzata con un originale intreccio realizzato in fibra vegetale o in cuoio.

Il disegno puro ed essenziale delle sedie Moka le colloca tra i prodotti destinati ad attraversare indenni il tempo e le mode.

Designed in 1939 by Mario Asnago and Claudio Vender, the Moka dining chair has been part of the Flexform collection since 1985. Mario Asnago and Claudio Vender began their professional partnership in the 1930s and are legitimately considered among the leading exponents of Italian rationalism.

Despite its age, the Moka dining chair is surprisingly modern and dense with design references reminiscent of pure rationalism.

The chair's structure is made of slender, elegant tubular metal and comes in painted black, white or aluminum color. The seat back features an elegant X-shaped design and the unique woven seat is made of plant fiber or cowhide.

The pure, uncomplicated design of the Moka dining chair places it among the products sure to remain untouched by the passage of time and fleeting fashions.





*The pure design of the Moka dining chair
lets it remain untouched by the passage
of time and fleeting fashion.*

TIPOLOGIE SEDIE/POLTRONCINE/SGABELLI - TAVOLI **PRODOTTO** SEDIA **STRUTTURA** IN METALLO VERNICIATO CON POLVERI EPOSSIDICHE NEI COLORI BIANCO, NERO, ALLUMINIO. APPOGGIO A TERRA SU PUNTALI IN MATERIALE TERMOPLASTICO **SEDUTA** IN CORDONCINO DI FIBRA VEGETALE O IN CUOIO NEI COLORI BIANCO 5007, GRIGIO 5003, TESTA DI MORO 5004, TESTA DI MORO SCURO 5013, NERO 5005, OLIVA 5006, ROSSO BULGARO 5008, SABBIA 5001, TABACCO 5015

CATEGORIES DINING CHAIRS/DINING ARMCHAIRS/BAR STOOLS - TABLES **PRODUCT** DINING CHAIR **STRUCTURE** IN EPOXY POWDER-COATED METAL IN WHITE, BLACK OR ALUMINUM COLOR. RESTS ON PADS MADE OF THERMOPLASTIC MATERIAL **SEAT** IN CORDED PLANT FIBER, OR IN COWHIDE IN THE FOLLOWING COLORS: WHITE 5007, GREY 5003, DARK BROWN 5004, EXTRA DARK BROWN 5013, BLACK 5005, OLIVE 5006, BULGARIAN RED 5008, SAND 5001 OR TOBACCO 5015

14501

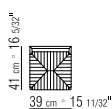
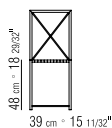
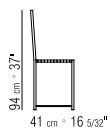

14531

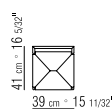
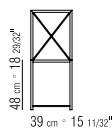
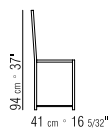

Moka

Data Sheet

Morgan

Antonio Citterio 2011

60

DINING CHAIRS DINING ARMCHAIRS BAR STOOLS



Poltrona, poltroncina e sgabello, Morgan è un prodotto caratterizzato da un'estetica asciutta e funzionale.

L'essenziale struttura in metallo è proposta nelle finiture satinato, cromato, brunito, cromo nero e champagne e corre leggera come un nastro ad abbracciare lo schienale in legno massello e la seduta imbottita.

La sobria eleganza della poltroncina e dello sgabello Morgan ne fanno dei prodotti duttili e versatili, adatti ad arredare sia ambienti domestici che spazi pubblici come ristoranti, bar, lounge.

Armchair, dining armchair and bar stool, Morgan is a product with a lean, functional aesthetic.

The austere metal structure comes in satin, chrome, burnished, black chrome or champagne finish and curls around, light-as-a-ribbon, to embrace the solid wood seat back and upholstered seat cushion.

The restrained elegance of the Morgan dining armchair and bar stool highlights their versatility and adaptability, suited to furnishing both residential settings and public spaces, like restaurants, bars and lounges.



62







TIPOLOGIE POLTRONE/POUF - SEDIE/POLTRONCINE/SGABELLI **PRODOTTO** POLTRONCINA - SGABELLO **STRUTTURA** IN METALLO NELLE FINITURE SATINATO, CROMATO, CROMO NERO, BRUNITO, CHAMPAGNE **SEDUTA** IN LEGNO MULTISTRATO CON IMBOTTITURA IN POLIURETANO ESPANSO RIVESTITA IN TESSUTO PROTETTIVO ACCOPPIATO **SCHIENALE** IN LEGNO MASSELLO DI NOCE CANALETTO NELLE FINITURE NATURALE, TINTO EXTRA, TINTO CAFFÈ O MASSELLO DI FRASSINO NELLE FINITURE NATURALE, TINTO NOCE, TINTO CILIEGIO, TINTO TEAK, TINTO CAFFÈ, TINTO WENGÉ, TINTO EBANO, TINTO MARRONE **RIVESTIMENTO** NON SFODERABILE SIA NELLA VERSIONE IN TESSUTO CHE NELLA VERSIONE IN PELLE

CATEGORIES ARMCHAIRS/POUF - DINING CHAIRS/DINING ARMCHAIRS/BAR STOOLS **PRODUCT** DINING ARMCHAIR - BAR STOOL **STRUCTURE** IN METAL WITH SATIN, CHROME, BLACK CHROME, BURNISHED OR CHAMPAGNE FINISH **SEAT** IN PLYWOOD WITH POLYURETHANE FOAM PADDING, COVERED WITH A PROTECTIVE LAMINATED FABRIC **BACKREST** IN SOLID CANALETTO WALNUT WITH NATURAL FINISH, OR STAINED CANALETTO WALNUT EXTRA OR COFFEE; OR, IN SOLID ASH WITH NATURAL FINISH OR STAINED WALNUT, CHERRY, TEAK, COFFEE, WENGE, EBONY OR BROWN **UPHOLSTERY** IS NON-REMOVABLE IN BOTH THE FABRIC AND LEATHER VERSIONS

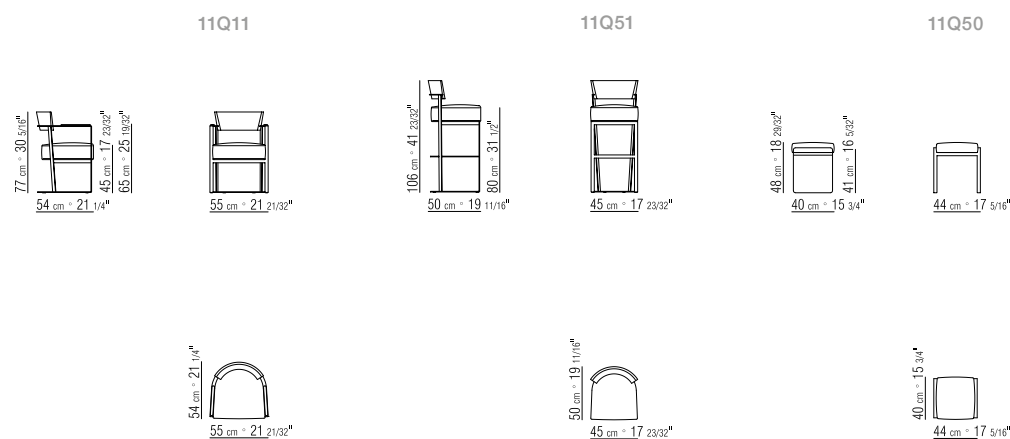

Morgan
Data Sheet



**DINING CHAIRS
DINING ARMCHAIRS
BAR STOOLS**

La famiglia di sedute Ortigia comprende anche raffinate sedie e poltroncine da pranzo.

La struttura è interamente realizzata in massello di noce canaletto o frassino, lavorato con tecniche che rimandano alla tradizione ebanista, mentre lo schienale è caratterizzato da un sofisticato intreccio in cuoio confezionato a mano.

La seduta imbottita può essere rivestita in tutti i tessuti e le pelli dell'esclusiva collezione Flexform.

The Ortigia family of seating elements also includes elegant chairs and dining chairs. The structure is made entirely of solid Canaletto walnut or ash, artisan-crafted with techniques that call to mind the fine cabinetmaking tradition, while the sophisticated backrest is made of hand-woven cowhide cord. The padded seat cushion can be upholstered in any of the fabrics or leathers from the exclusive Flexform collection.





TIPOLOGIE POLTRONE/POUF - POLTRONCINE/SEDIE/SGABELLI **PRODOTTO** POLTRONCINA - SGABELLO **STRUTTURA E SCHIENALE** IN LEGNO MASSELLO DI NOCE CANALETTO NELLE FINITURE NATURALE, TINTO EXTRA, TINTO CAFFÈ O MASSELLO DI FRASSINO NELLE FINITURE NATURALE, TINTO NOCE, TINTO CILIEGIO, TINTO TEAK, TINTO CAFFÈ, TINTO WENGÉ, TINTO EBANO, TINTO MARRONE. INTRECCIO IN CUIOIO NEI COLORI BIANCO 5007, GRIGIO 5003, TESTADI MORO 5004, TESTADI MORO SCURO 5013, NERO 5005, OLIVA 5006, ROSSO BULGARO 5008, SABBIA 5001, TABACCO 5015 **PIEDI** IN ZAMA PRESSOFUSA NELLE FINITURE SATINATO, CROMATO, CROMO NERO, BRUNITO, CHAMPAGNE. APPOGGIO A TERRA SU PUNTALI IN MATERIALE TERMOPLASTICO **SEDUTA** IN LEGNO MULTISTRATO CON IMBOTTITURA IN POLIURETANO ESPANSO RIVESTITA IN TESSUTO PROTETTIVO ACCOPPIATO **RIVESTIMENTO** SFODERABILE SIA NELLA VERSIONE IN TESSUTO CHE NELLA VERSIONE IN PELLE

CATEGORIES ARMCHAIRS/OTTOMANS - DINING ARMCHAIRS/CHAIRS/BAR STOOLS **PRODUCT** DINING ARMCHAIRS - OTTOMANS **STRUCTURE AND BACKREST** IN SOLID CANALETTO WALNUT WITH NATURAL FINISH, STAINED CANALETTO WALNUT EXTRA OR COFFEE; OR, IN SOLID ASH WITH NATURAL FINISH OR STAINED WALNUT, CHERRY, TEAK, COFFEE, WENGE, EBONY OR BROWN. WOVEN COWHIDE IN THE FOLLOWING COLORS: WHITE 5007, GREY 5003, DARK BROWN 5004, EXTRA DARK BROWN 5013, BLACK 5005, OLIVE 5006, BULGARIAN RED 5008, SAND 5001, TOBACCO 5015 **FEET** IN DIE-CAST ZAMA WITH SATIN, CHROME, BLACK CHROME, BURNISHED OR CHAMPAGNE FINISH. RESTS ON PADS MADE OF THERMOPLASTIC MATERIAL **SEAT** IN PLYWOOD WITH POLYURETHANE FOAM PADDING, COVERED WITH A PROTECTIVE LAMINATED FABRIC **UPHOLSTERY** IS REMOVABLE IN BOTH THE FABRIC AND LEATHER VERSIONS

25611/25612

25651/25653

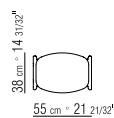
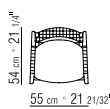
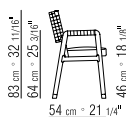

Pat

Design Center 1997

70



DINING CHAIRS DINING ARMCHAIRS BAR STOOLS

Sedia e poltroncina da pranzo, Pat è contraddistinta da una linea pulita ed essenziale, al di là del tempo e delle mode.

Le slanciate gambe a sezione quadrata sono in massello di noce canaletto e frassino, tinti in una pluralità di nuance.

Pat è un prodotto trasversale che risponde alle esigenze più diverse, facile da collocare in ambienti di gusto classico oppure contemporaneo, in abbinamento a qualsiasi tipo di tavolo.

Il rivestimento completamente sfoderabile, sia in tessuto che in pelle, consente a Pat di inserirsi agilmente anche in spazi hospitality quali bar e ristoranti.

The clean, uncluttered lines of the Pat dining chair and dining armchair transcend the bounds of time and fashion.

The sleek, square legs come in solid Canaletto walnut or ash, available in a number of different stains.

Pat is a versatile product designed to meet the most diverse needs, effortlessly at home in settings with a classic or contemporary style signature and can be paired with any kind of table.

The completely removable upholstery, whether in fabric or leather, gives Pat the freedom to also furnish hospitality spaces like bars and restaurants with a carefree spirit.



72



TIPOLOGIE POLTRONE/POUF - SEDIE/POLTRONCINE/SGABELLI **PRODOTTO** POLTRONCINA - SEDIA **STRUTTURA** IN METALLO E POLIURETANO STAMPATO RIVESTITA IN TESSUTO PROTETTIVO ACCOPPIATO **CUSCINO SEDUTA** IN POLIURETANO ESPANSO E DACRON **GAMBE** IN LEGNO MASSELLO DI NOCE CANALETTO NELLE FINITURE NATURALE, TINTO EXTRA, TINTO CAFFÈ O MASSELLO DI FRASSINO NELLE FINITURE NATURALE, TINTO NOCE, TINTO CILIEGIO, TINTO TEAK, TINTO CAFFÈ, TINTO WENGÉ, TINTO EBANO, TINTO MARRONE **RIVESTIMENTO** SFODERABILE SIA NELLA VERSIONE IN TESSUTO CHE NELLA VERSIONE IN PELLE **PROFILO** RIVESTIMENTO CUSCINO SEDUTA LA CONFEZIONE PREVEDE UN PROFILO IN GROS GRAIN CHE PUÒ ESSERE REALIZZATO IN TUTTI I COLORI DELLA CARTELLA CAMPIONI

CATEGORIES ARMCHAIRS/POUF - DINING CHAIRS/DINING ARMCHAIRS/BAR STOOLS **PRODUCT** DINING ARMCHAIR - DINING CHAIR **STRUCTURE** IN METAL AND MOLDED POLYURETHANE, COVERED WITH A PROTECTIVE LAMINATED FABRIC **SEAT CUSHION** IN POLYURETHANE FOAM AND DACRON **LEGS** IN SOLID CANALETTO WALNUT WITH NATURAL FINISH, OR STAINED CANALETTO WALNUT EXTRA OR COFFEE; OR, IN SOLID ASH WITH NATURAL FINISH OR STAINED WALNUT, CHERRY, TEAK, COFFEE, WENGE, EBONY OR BROWN **UPHOLSTERY** IS REMOVABLE IN BOTH THE FABRIC AND LEATHER VERSIONS **SEAT CUSHION PIPING** - UPHOLSTERY DETAILING INCLUDES GROSGRAIN PIPING THAT CAN BE CRAFTED IN ALL THE COLORS ON THE SAMPLE BOARD

12203



12202

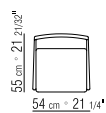
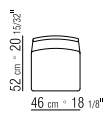
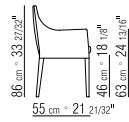

Pat

Data Sheet

Pausa

Design Center 1992

74

Pausa è sia sedia che poltroncina e presenta proporzioni studiate e dimensioni contenute.

Le linee sono gentili ed aggraziate e conferiscono alla poltroncina Pausa un'allure al di là del tempo e delle mode.

Le gambe sono in massello di noce canaletto e frassino, proposti in una varietà di tinte, che aumentano il carattere già versatile della sedia Pausa.

La poltroncina Pausa è dotata di una pratica maniglia sulla parte posteriore dello schienale e da ruote anteriori che consentono di spostarla agevolmente.

La housse di rivestimento, di facile rimozione sia nella versione in tessuto che in pelle, è proposta nelle varianti lunga e corta.

Pausa is both a chair and an armchair, with finely-engineered proportions and conservative dimensions.

Its delicate, graceful lines lend the Pausa armchair the kind of appeal that transcends the bounds of time and fashion.

The legs are in solid Canaletto walnut or ash, available in a number of stain finishes that enhance the already-versatile personality of the Pausa chair.

The Pausa armchair comes with a handle on the seat back and practical front casters that make it easy to move.

The slipcover, in either fabric or leather, is easy to remove and comes in both long and short versions.



**DINING CHAIRS
DINING ARMCHAIRS
BAR STOOLS**



76



TIPOLOGIE SEDIE/POLTRONCINE/SGABELLI **PRODOTTO** POLTRONCINA **STRUTTURA** IN METALLO CON IMBOTTITURA IN POLIURETANO STAMPATO RIVESTITO IN TESSUTO PROTETTIVO ACCOPPIATO **GAMBE** IN LEGNO MASSELLO DI NOCE CANALETTO NELLE FINITURE NATURALE, TINTO EXTRA, TINTO CAFFÈ O MASSELLO DI FRASSINO NELLE FINITURE NATURALE, TINTO NOCE, TINTO CILIEGIO, TINTO TEAK, TINTO CAFFÈ, TINTO WENGÉ, TINTO EBANO, TINTO MARRONE, CON RUOTE ANTERIORI IN METALLO E GOMMA. A RICHIESTA È DISPONIBILE ANCHE LA VERSIONE SENZA RUOTE **RIVESTIMENTO** SFODERABILE SIA NELLA VERSIONE IN TESSUTO CHE NELLA VERSIONE IN PELLE. DISPONIBILE NELLE VERSIONI CON FODERA LUNGA O CORTA

CATEGORIES DINING CHAIRS/DINING ARMCHAIRS/BAR STOOLS **PRODUCT** DINING ARMCHAIR **STRUCTURE** IN METAL WITH MOLDED POLYURETHANE PADDING, COVERED WITH A PROTECTIVE LAMINATED FABRIC **LEGS** IN SOLID CANALETTO WALNUT WITH NATURAL FINISH, OR STAINED CANALETTO WALNUT EXTRA OR COFFEE; OR, IN SOLID ASH WITH NATURAL FINISH OR STAINED WALNUT, CHERRY, TEAK, COFFEE, WENGE, EBONY OR BROWN, WITH FRONT CASTERS IN METAL AND RUBBER. UPON REQUEST, IT IS ALSO AVAILABLE WITHOUT CASTERS **UPHOLSTERY** IS REMOVABLE IN BOTH THE FABRIC AND LEATHER VERSIONS. AVAILABLE WITH LONG OR SHORT SLIPCOVER

13C01

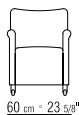
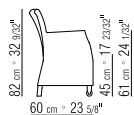

13C02

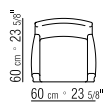
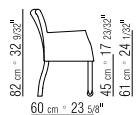

Pausa

Data Sheet

Tavoli

Tables

| | |
|----------|-----|
| CLARKE | 80 |
| DIDA | 84 |
| FLY | 88 |
| GIPSY | 94 |
| GUSTAV | 98 |
| ISEO | 104 |
| JIFF | 108 |
| MIXER | 112 |
| MOKA | 116 |
| MONREALE | 120 |
| SOFFIO | 124 |
| SPELLO | 128 |
| ZEFIRO | 132 |



Clarke

Carlo Colombo 2013

80

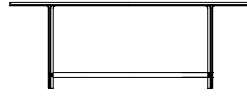

TABLES

Clarke è un raffinato tavolo da pranzo caratterizzato da una sofisticata struttura in metallo che costituisce sia la cornice sopra la quale viene collocato il piano in marmo sia la base del tavolo, contraddistinta da un elegante disegno della barra di raccordo delle gambe.

Alla linea essenziale del disegno si accompagna la scelta di materie di forte impatto scenico e di grande pregio: la base in metallo è proposta nelle finiture satinato, cromato, brunito, cromo nero e champagne; mentre il piano in marmo può essere realizzato nelle versioni Calacatta Oro, Emperador, Nero Marquina, Bianco Carrara.

Il piano di forma ovale è proposto in due dimensioni e consente di allocare comodamente da otto fino a dodici commensali.

Clarke is an elegant dining table whose sophisticated metal structure forms not only the frame upon which the marble top rests but also the base of the table, characterized by the exquisite design of the bar that joins the legs.

The table's sleek lines are complemented by the use of boldly dramatic and luxurious materials – the metal base comes in satin, chrome, burnished, black chrome or champagne finish, while the marble top can be crafted in Calacatta Gold, Emperador, Black Marquina or White Carrara marble.

The oval top comes in two sizes and will seat eight to twelve diners comfortably around the table.





TIPOLOGIE TAVOLI - TAVOLINI/CONSOLLE **PRODOTTO TAVOLO STRUTTURA**
 IN METALLO NELLE FINITURE SATINATO, CROMATO, CROMO NERO, BRUNITO,
 CHAMPAGNE. APPOGGIO A TERRA SU PUNTALI IN MATERIALE TERMOPLASTICO
PIANO IN MARMO NELLE TIPOLOGIE CALACATTA ORO LUCIDO, MARMO CALACATTA
 ORO OPACO, BIANCO CARRARA LUCIDO, NERO MARQUINIA LUCIDO, EMPERADOR
 LUCIDO, EMPERADOR OPACO

CATEGORIES TABLES - COFFEE TABLES/SIDE TABLES/CONSOLES **PRODUCT TABLE**
STRUCTURE IN METAL WITH SATIN, CHROME, BLACK CHROME, BURNISHED
 OR CHAMPAGNE FINISH. RESTS ON PADS MADE OF THERMOPLASTIC MATERIAL
TOP IN THE FOLLOWING TYPES OF MARBLE: CALACATTA GOLD POLISHED OR
 MATTE, POLISHED WHITE CARRARA, POLISHED BLACK MARQUINA, EMPERADOR
 POLISHED OR MATTE

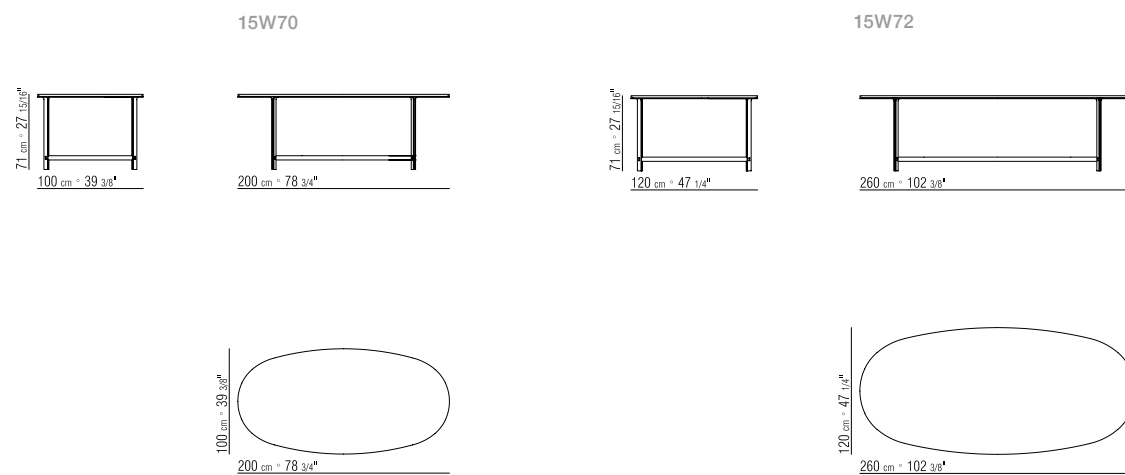

Clarke
Data Sheet

Chiari riferimenti alla tradizione ebanista per il tavolo Dida, seppure rivisitata in chiave contemporanea.

Le gambe rastremate danno slancio al piano in marmo, incastonato come una pietra preziosa dentro una cornice in legno massello dal forte spessore e con bordo smussato.

La matericità del legno di frassino tinto in una pluralità di finiture incontra la raffinatezza del marmo, proposto nelle varianti Calacatta Oro, Emperador, Nero Marquinia e Bianco Carrara.

Il tavolo Dida ha dimensioni contenute che ne consentono l'inserimento anche in ambienti non particolarmente ampi.

Though updated with a contemporary flair, the Dida table clearly exhibits its heritage of fine cabinetry tradition.

The tapered legs lend a dash of vitality to the marble top, set like a precious jewel in the table's substantial solid-wood frame with beveled edge.

The physicality of the ash wood, stained in any number of finishes, blends charmingly with the refinement of the marble top, available in Calacatta Gold, Emperador, Black Marquina or White Carrara.

The smaller scale of the Dida table allows it to fit comfortably even in more modestly-proportioned rooms.

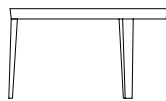

TABLES





TIPOLOGIE TAVOLI - TAVOLINI/CONSOLLE **PRODOTTO** TAVOLO **STRUTTURA** IN LEGNO MASSELLO DI FRASSINO NELLE FINITURE NATURALE, TINTO NOCE, TINTO CILIEGIO, TINTO TEAK, TINTO CAFFÈ, TINTO WENGÉ, TINTO EBANO, TINTO MARRONE. APPOGGIO A TERRA SU PUNTALI IN MATERIALE TERMOPLASTICO **PIANO** IN MARMO NELLE TIPOLOGIE CALACATTA ORO LUCIDO, MARMO CALACATTA ORO OPACO, BIANCO CARRARA LUCIDO, NERO MARQUINIA LUCIDO, EMPERADOR LUCIDO, EMPERADOR OPACO

CATEGORIES TABLES - COFFEE TABLES/SIDE TABLES/CONSOLES **PRODUCT** TABLE **STRUCTURE** IN SOLID ASH WITH NATURAL FINISH OR STAINED WALNUT, CHERRY, TEAK, COFFEE, WENGE, EBONY OR BROWN. RESTS ON PADS MADE OF THERMOPLASTIC MATERIAL **TOP** IN THE FOLLOWING TYPES OF MARBLE: CALACATTA GOLD POLISHED OR MATTE, POLISHED WHITE CARRARA, POLISHED BLACK MARQUINA, EMPERADOR POLISHED OR MATTE

14Z78

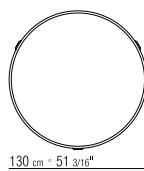
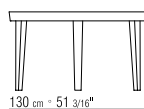
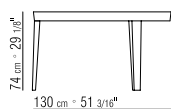

Dida
Data Sheet

Fly

Antonio Citterio 2009



Un'ampia famiglia di tavoli, tavolini e contenitori caratterizzata da una grande trasversalità, autentica espressione di quel "good design" al quale è improntata tutta la collezione Flexform.

La purezza del disegno unita ad una grande praticità, la varietà di finiture e misure fanno del tavolo Fly un prodotto estremamente versatile.

La base del tavolo è in metallo nelle finiture satinato, cromato, brunito, cromo nero e champagne mentre il piano – proposto nelle varianti tondo, ovale, rettangolare in una pluralità di misure – è proposto in noce canaletto e frassino tinti in molteplici nuance o in marmo.

Il tavolo rettangolare è previsto anche nella versione allungabile.

An extensive family of extremely versatile tables, coffee tables, side tables and cabinets, Fly is a genuine expression of the kind of "good design" upon which the entire Flexform collection is built.

Purity of design, along with true practicality and the variety of finishes and sizes available, imbue the Fly table with amazing versatility.

The table's metal base comes in satin, chrome, burnished, black chrome or champagne finish, while the top – available in round, oval or rectangular shape, and in a number of sizes – comes in Canaletto walnut or ash, stained in an array of shades, or in marble.

An extendable version of the rectangular table is also available.



TABLES





Modern design along with genuine practicality and a wide variety of sizes and finishes imbue the Fly table with amazing versatility.



TIPOLOGIE TAVOLI - TAVOLINI/CONSOLLE - LIBRERIE/CONTENITORI/COMPLEMENTI
PRODOTTO TAVOLO – TAVOLO ALLUNGABILE **STRUTTURA** IN METALLO NELLE
FINITURE SATINATO, CROMATO, CROMO NERO, BRUNITO, CHAMPAGNE. APPOGGIO
A TERRA SU PUNTALI IN MATERIALE TERMOPLASTICO **PIANO COD 14X77-14X78** IN
LEGNO MASSELLO DI NOCE CANALETTO NELLE FINITURE NATURALE, TINTO EXTRA,
TINTO CAFFÈ O MASSELLO DI FRASSINO NELLE FINITURE NATURALE, TINTO NOCE,
TINTO CILIEGIO, TINTO TEAK, TINTO CAFFÈ, TINTO WENGÉ, TINTO EBANO, TINTO
MARRONE O IN MARMO NELLE TIPOLOGIE CALACATTA ORO LUCIDO, MARMO
CALACATTA ORO OPACO, BIANCO CARRARA LUCIDO, NERO MARQUINIA LUCIDO,
EMPERADOR LUCIDO, EMPERADOR OPACO **PIANO COD 14X73-14X70-14X71-14X72-
14X74** IN LEGNO IMPIALLACCIATO DI NOCE CANALETTO NELLE FINITURE NATURALE,
TINTO EXTRA, TINTO CAFFÈ O DI FRASSINO NELLE FINITURE NATURALE, TINTO
NOCE, TINTO CILIEGIO, TINTO TEAK, TINTO CAFFÈ, TINTO WENGÉ, TINTO EBANO,
TINTO MARRONE **PIANO COD 14X84-14X86** IN MARMO NELLE TIPOLOGIE CALACATTA
ORO LUCIDO, MARMO CALACATTA ORO OPACO, BIANCO CARRARA LUCIDO, NERO
MARQUINIA LUCIDO, EMPERADOR LUCIDO, EMPERADOR OPACO

CATEGORIES TABLES - COFFEE TABLE/SIDE TABLES/CONSOLES - BOOKSHELVES/
CABINETS/ACCESSORIES **PRODUCT** TABLE **STRUCTURE** IN METAL WITH SATIN,
CHROME, BLACK CHROME, BURNISHED OR CHAMPAGNE FINISH. RESTS ON PADS
MADE OF THERMOPLASTIC MATERIAL **TOP COD 14X77-14X78** IN SOLID CANALETTO
WALNUT WITH NATURAL FINISH, OR STAINED CANALETTO WALNUT EXTRA OR
COFFEE; OR, IN SOLID ASH WITH NATURAL FINISH OR STAINED WALNUT, CHERRY,
TEAK, COFFEE, WENGE, EBONY OR BROWN; OR, IN THE FOLLOWING TYPES OF
MARBLE: CALACATTA GOLD POLISHED OR MATTE, POLISHED WHITE CARRARA,
POLISHED BLACK MARQUINA, EMPERADOR POLISHED OR MATTE **TOP COD 14X73-
14X70-14X71-14X72-14X74** IN CANALETTO WALNUT VENEER WITH NATURAL FINISH
OR STAINED CANALETTO WALNUT EXTRA OR COFFEE; OR, IN ASH WITH NATURAL
FINISH OR STAINED WALNUT, CHERRY, TEAK, COFFEE, WENGE, EBONY OR BROWN
TOP COD 14X84-14X86 IN THE FOLLOWING TYPES OF MARBLE: CALACATTA GOLD
POLISHED OR MATTE, POLISHED WHITE CARRARA, POLISHED BLACK MARQUINA,
EMPERADOR POLISHED OR MATTE

14X77

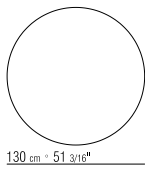
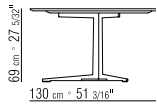

14X78

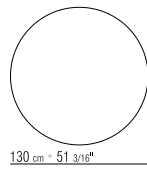
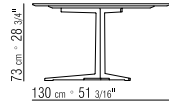

14X84

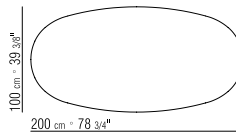
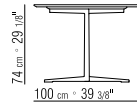

14X86

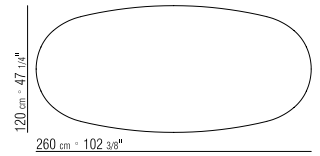
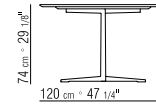

14X73

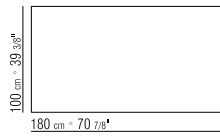
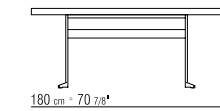
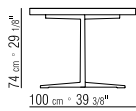

14X70

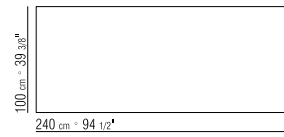
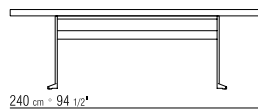

14X72

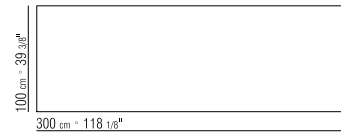
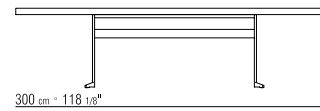

14X71

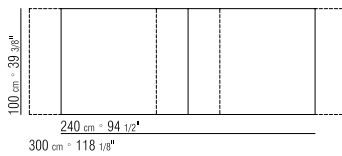
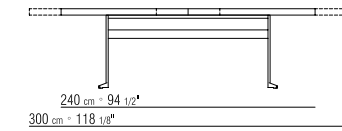
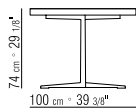

14X74

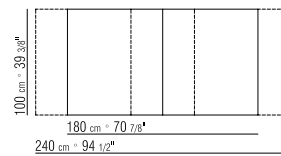
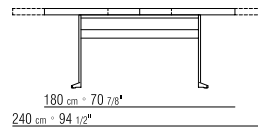

Gipsy

Antonio Citterio 2013

94

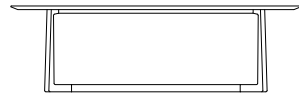

TABLES

La collezione di tavoli, tavolini e consolle Gipsy è caratterizzata da linee pulite e durature.

Il tavolo Gipsy presenta una raffinata base in massello di noce canaletto e frassino in una varietà di tinte.

La ricercata lavorazione della gamba a sezione quadrata che si congiunge nella base di appoggio a terra con un bel gioco di geometrie esalta la poetica matericità del legno e crea un interessante contrasto con il piano proposto nelle versioni laccato lucido o vetro retro-verniciato in sofisticate nuance.

Il piano rettangolare è contraddistinto da un interessante disegno più affilato sui lati capotavola e stondato sui lati lunghi.

The Gipsy collection of tables, coffee tables and consoles features clean, timeless lines.

The elegant base of the Gipsy table is made of solid Canaletto walnut or ash, available in a number of stain finishes.

The sophisticated workmanship of the square legs that join the support base in a lively interplay of geometries heightens the poetic texture and feel of the wood, creating a delightful contrast with the top, which comes in versions with glossy lacquer finish or back-painted glass, in a sophisticated palette of colors.

The rectangular table top features an attractive silhouette that is more slender at the head and foot and slightly curved on the long edges.





TIPOLOGIE TAVOLI - TAVOLINI/CONSOLLE **PRODOTTO TAVOLO STRUTTURA** IN LEGNO MASSELLO DI NOCE CANALETTO NELLE FINITURE NATURALE, TINTO EXTRA, TINTO CAFFÈ O MASSELLO DI FRASSINO NELLE FINITURE NATURALE, TINTO NOCE, TINTO CILIEGIO, TINTO TEAK, TINTO COLORE CAFFÈ, TINTO WENGÉ, TINTO EBANO, TINTO MARRONE. APPOGGIO A TERRA SU PUNTALI IN MATERIALE TERMOPLASTICO PIANO IN LEGNO LACCATO LUCIDO NELLE FINITURE BIANCO, NERO, LILLA, GRIGIO VERDE, MOKA, SALMONE, TORTORA, VERDE PINO O IN VETRO RETROVERNICIATO NEI COLORI BIANCO SETA, CAFFÈ, GRIGIO, NERO

CATEGORIES TABLES - COFFEE TABLES/SIDE TABLES/CONSOLES **PRODUCT TABLE STRUCTURE** IN SOLID CANALETTO WALNUT WITH NATURAL FINISH, OR STAINED CANALETTO WALNUT EXTRA OR COFFEE; OR, IN SOLID ASH WITH NATURAL FINISH OR STAINED WALNUT, CHERRY, TEAK, COFFEE, WENGE, EBONY OR BROWN. RESTS ON PADS MADE OF THERMOPLASTIC MATERIAL **TOP** IN WOOD WITH GLOSSY LACQUER FINISH IN WHITE, BLACK, LILAC, GREY-GREEN, MOCHA, SALMON PINK, DOVE GREY OR PINE GREEN OR WITH BACKPAINTED GLASS TOP IN SILK WHITE, COFFEE, GREY OR BLACK

20183

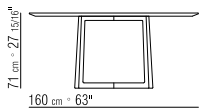

160 cm • 63"

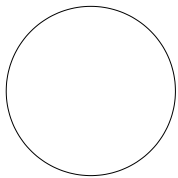

160 cm • 63"

20180

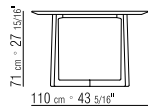

110 cm • 43 5/16"

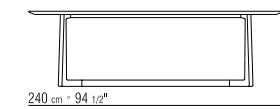

240 cm • 94 1/2"

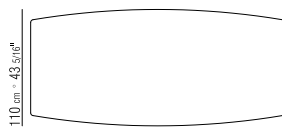

240 cm • 94 1/2"

20181



300 cm • 118 1/8"

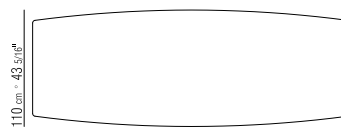

300 cm • 118 1/8"

Gipsy
Data Sheet

Gustav

Carlo Colombo 2018

98

Il disegno del tavolo Gustav rivela il gusto per il dettaglio ricercato come quello rappresentato dall'innesto della gamba tornita in legno massello con il piano del tavolo. Un particolare all'apparenza semplice che nasconde tuttavia una notevole complessità sul piano costruttivo.

Il tavolo Gustav è realizzato nelle versioni tondo e rettangolare, in diverse misure ed è proposto in una serie di originali combinazioni materiche tra la struttura in massello di noce canaletto o frassino in una pluralità di tinte e il piano in marmo nelle varietà Bianco Carrara, Nero Marquina, Calacatta Oro ed Emperador.

The Gustav table reveals a flair for sophisticated design details, like the point where the solid wood turned leg is joined to the table top. This seemingly simple detail requires complex construction finesse that remains entirely out of sight.

Available in round and rectangular versions, the Gustav table comes in several sizes and in a series of unique combinations between the structure in solid Canaletto walnut or ash, stained in a number of tints, and a choice of marble for the top: White Carrara, Nero Marquina, Calacatta Gold or Emperador.



TABLES



100



Purity of design and exquisite combinations of materials set the Gustav dining table apart and make for the perfect complement to the many dining chairs in the Flexform collection.



TIPOLOGIE TAVOLI - TAVOLINI/CONSOLLE **PRODOTTO** TAVOLO **STRUTTURA**
IN LEGNO MASSELLO DI NOCE CANALETTO NELLE FINITURE NATURALE, TINTO
EXTRA, TINTO CAFFÈ O MASSELLO DI FRASSINO NELLE FINITURE NATURALE,
TINTO NOCE, TINTO CILIEGIO, TINTO TEAK, TINTO CAFFÈ, TINTO WENGÉ, TINTO
EBANO, TINTO MARRONE. APPOGGIO A TERRA SU PUNTALI IN MATERIALE
TERMOPLASTICO **PIANO** IN MARMO NELLE TIPOLOGIE CALACATTA ORO LUCIDO,
MARMO CALACATTA ORO OPACO, BIANCO CARRARA LUCIDO, NERO MARQUINIA
LUCIDO, EMPERADOR LUCIDO, EMPERADOR OPACO

CATEGORIES TABLES - COFFEE TABLES/SIDE TABLES/CONSOLES **PRODUCT** TABLE
STRUCTURE IN SOLID CANALETTO WALNUT WITH NATURAL FINISH, OR STAINED
CANALETTO WALNUT EXTRA OR COFFEE; OR, IN SOLID ASH WITH NATURAL FINISH
OR STAINED WALNUT, CHERRY, TEAK, COFFEE, WENGE, EBONY OR BROWN. RESTS
ON PADS MADE OF THERMOPLASTIC MATERIAL **TOP** IN THE FOLLOWING TYPES OF
MARBLE: CALACATTA GOLD POLISHED OR MATTE, POLISHED WHITE CARRARA,
POLISHED BLACK MARQUINA, EMPERADOR POLISHED OR MATTE

24981/24983

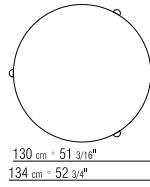
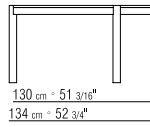
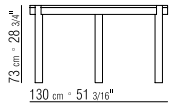

24982/24984

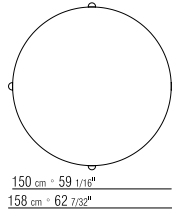
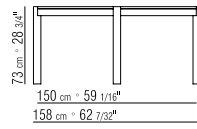

24985/24987

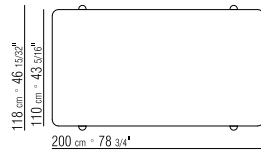
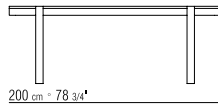
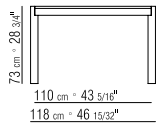

24986/24988

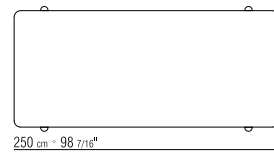
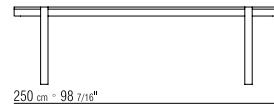
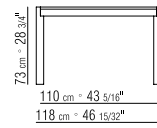



TABLES

Iseo rappresenta l'archetipo del tavolo nella semplicità della forma e si presenta perfettamente equilibrato nelle proporzioni e negli spessori.

La raffinata base è all'insegna della pulizia formale e della sottrazione estetica: le quattro gambe in metallo dalla sezione rastremata e con spigolo smussato sono posizionate a filo ai quattro angoli esterni del tavolo e sorreggono il piano costituito da una sottile lastra di marmo o legno.

Ciò che contraddistingue il tavolo Iseo è la ricercata combinazione materica tra la struttura in metallo proposta nelle finiture satinato, cromato, cromo nero, brunito e champagne e il piano che può essere realizzato in essenza – noce canaletto e frassino tinti in numerose nuance – oppure in prezioso marmo.

The simplicity of its lines and perfectly balanced proportions make Iseo the archetypal table.

The elegant base is an exercise in formal purity and subtractive design – the four tapered metal legs with beveled edges are set flush with the four outer corners of the table and support the top made of a thin slab of marble or wood.

Iseo's magnetic personality derives from the sophisticated textural juxtaposition between the metal structure, available in satin, chrome, burnished, black chrome or champagne finish, and the top, which can be crafted in wood – Canaletto walnut or ash, stained in an array of shades – or in luxurious marble.



106



TIPOLOGIE TAVOLI PRODOTTO TAVOLO STRUTTURA IN METALLO NELLE FINITURE SATINATO, CROMATO, CROMO NERO, BRUNITO, CHAMPAGNE **PIANO** IN LEGNO IMPIALLACCIATO DI NOCE CANALETTO NELLE FINITURE NATURALE, TINTO EXTRA, TINTO CAFFÈ O IMPIALLACCIATO DI FRASSINO NELLE FINITURE NATURALE, TINTO NOCE, TINTO CILIEGIO, TINTO TEAK, TINTO CAFFÈ, TINTO WENGÉ, TINTO EBANO, TINTO MARRONE O IN MARMO NELLE TIPOLOGIE CALACATTA ORO LUCIDO, MARMO CALACATTA ORO OPACO, BIANCO CARRARA LUCIDO, NERO MARQUINIA LUCIDO, EMPERADOR LUCIDO, EMPERADOR OPACO. PANNELLO DI SUPPORTO IN LEGNO MULTISTRATO

CATEGORIES TABLES PRODUCT TABLE STRUCTURE IN METAL WITH SATIN, CHROME, BLACK CHROME, BURNISHED OR CHAMPAGNE FINISH **TOP** IN CANALETTO WALNUT VENEER WITH NATURAL FINISH, OR STAINED CANALETTO WALNUT EXTRA OR COFFEE; OR, IN ASH VENEER WITH NATURAL FINISH OR STAINED WALNUT, CHERRY, TEAK, COFFEE, WENGE, EBONY OR BROWN; OR, IN THE FOLLOWING TYPES OF MARBLE: CALACATTA GOLD POLISHED OR MATTE, POLISHED WHITE CARRARA, POLISHED BLACK MARQUINA, EMPERADOR POLISHED OR MATTE. PLYWOOD SUPPORT PANEL

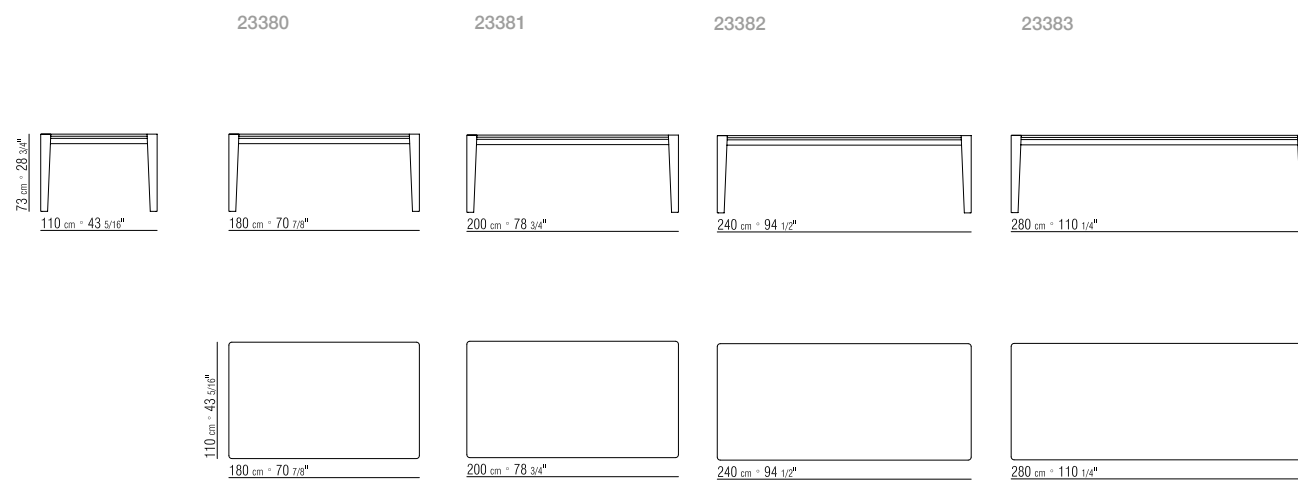

Iseo

Data Sheet

Alla purezza del disegno e alla ricercatezza dei dettagli costruttivi che caratterizzano il tavolo Jiff, si accompagna la scelta di un concept monomaterico, che si esprime nella scelta di un materiale caldo ed espressivo come il legno.

Solo ed unicamente legno – noce canaletto e frassino proposti in una varietà di tinte raffinate – massello per la struttura ed impiallacciato per il piano dai bordi smussati.

Originale e ad effetto il disegno delle quattro gambe che confluiscono unendosi alla base e in un unico elemento longitudinale parallelo al piano.

The Jiff table exhibits a purity of design and refined construction details that marry well with the 'monomaterial' concept conveyed through a warm, vibrant material like wood.

Made solely and exclusively of wood – Canaletto walnut or ash, available in a number of sophisticated stain finishes – solid wood is used for the structure and veneer for the beveled-edge top.

The lyrical design impact of the four legs that flow together, joining at the base to form a single longitudinal element parallel to the top, is unique and striking.

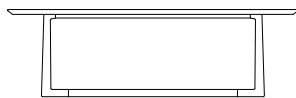

TABLES



110



TIPOLOGIE TAVOLI - TAVOLINI/CONSOLLE **PRODOTTO** TAVOLO **STRUTTURA** IN LEGNO MASSELLO DI NOCE CANALETTO NELLE FINITURE NATURALE, TINTO EXTRA, TINTO CAFFÈ O MASSELLO DI FRASSINO NELLE FINITURE NATURALE, TINTO NOCE, TINTO CILIEGIO, TINTO TEAK, TINTO CAFFÈ, TINTO WENGÉ, TINTO EBANO, TINTO MARRONE. APPOGGIO A TERRA SU PUNTALI IN MATERIALE TERMOPLASTICO **PIANO** IN LEGNO IMPIALLACCIATO DI NOCE CANALETTO NELLE FINITURE NATURALE, TINTO EXTRA, TINTO CAFFÈ O IMPIALLACCIATO DI FRASSINO NELLE FINITURE NATURALE, TINTO NOCE, TINTO CILIEGIO, TINTO TEAK, TINTO CAFFÈ, TINTO WENGÉ, TINTO EBANO, TINTO MARRONE

CATEGORIES TABLES - COFFEE TABLES/SIDE TABLES/CONSOLES **PRODUCT** TABLE **STRUCTURE** IN SOLID CANALETTO WALNUT WITH NATURAL FINISH, OR STAINED CANALETTO WALNUT EXTRA OR COFFEE; OR, IN SOLID ASH WITH NATURAL FINISH OR STAINED WALNUT, CHERRY, TEAK, COFFEE, WENGE, EBONY OR BROWN. RESTS ON PADS MADE OF THERMOPLASTIC MATERIAL **TOP** IN CANALETTO WALNUT VENEER WITH NATURAL FINISH, OR STAINED CANALETTO WALNUT EXTRA OR COFFEE; OR, IN ASH VENEER WITH NATURAL FINISH OR STAINED WALNUT, CHERRY, TEAK, COFFEE, WENGE, EBONY OR BROWN

11Z80

11Z81

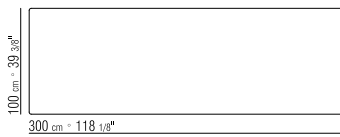
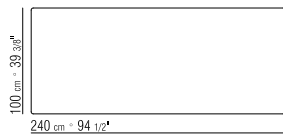
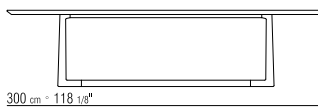
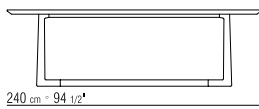
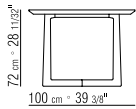

Jiff
Data Sheet

Mixer

Design Center 1985

112

Mixer è un tavolo connotato da una grande concretezza progettuale, polivalente in termini di utilizzo e che si presta ad essere facilmente inserito sia in ambienti domestici, sia in uffici o in sale riunioni.

Le essenziali gambe in metallo sono proposte nelle finiture satinato, alluminio o verniciate in colore nero e sono dotate di ruote pivotanti autobloccanti che rendono il tavolo Mixer ancora più agile e funzionale. Il piano è impiallacciato in noce canaletto o frassino in un'ampia gamma di tinte e oltre che nella versione rettangolare è disponibile anche nell'originale forma sagomata "a fagiolo" progettata nell'ottica di offrire una soluzione ideale per l'home office.

Thanks to its very down-to-earth design bones, Mixer is a table that can be put to many kinds of use, designed to fit well in residential settings or in offices or conference rooms.

The uncomplicated metal legs come in satin finish or painted black or aluminum color and are equipped with self-locking swivel casters that make Mixer even more fleet-footed and functional.

The top is in Canaletto walnut or ash veneer, in a wide range of stains. In addition to the rectangular version, Mixer is also available in a unique contoured "kidney-bean" shape, designed as an ideal solution for the home office.



TABLES



114



TIPOLOGIE POLTRONCINE/SEDIE/SGABELLI - TAVOLI **PRODOTTO** TAVOLO - TAVOLO A FAGIOLO **PIANO** IN LEGNO IMPIALLACCIATO DI NOCE CANALETTO NELLE FINITURE NATURALE, TINTO EXTRA, TINTO CAFFÈ O IMPIALLACCIATO DI FRASSINO NELLE FINITURE NATURALE, TINTO NOCE, TINTO CILIEGIO, TINTO TEAK, TINTO CAFFÈ, TINTO WENGÉ, TINTO EBANO, TINTO MARRONE **GAMBE** IN METALLO NELLE FINITURE NERO, ALLUMINIO, SATINATA. CON RUOTE AUTOBLOCCANTI

CATEGORIES SMALL ARMCHAIRS/CHAIRS/STOOLS - TABLES **PRODUCT** TABLE **TOP** IN CANALETTO WALNUT VENEER WITH NATURAL FINISH, OR STAINED CANALETTO WALNUT EXTRA OR COFFEE; OR, IN ASH VENEER WITH NATURAL FINISH OR STAINED WALNUT, CHERRY, TEAK, COFFEE, WENGE, EBONY OR BROWN **LEGS** IN METAL WITH BLACK, ALUMINUM OR SATIN FINISH. WITH SELF-LOCKING SPINNER WHEELS

13094

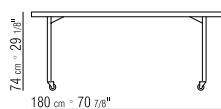

13092



13093

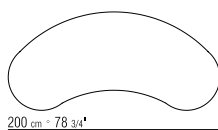
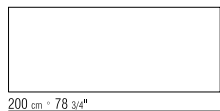
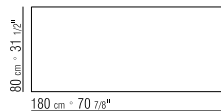
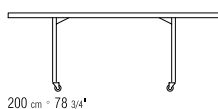

Mixer
Data Sheet

Moka

Mario Asnago | Claudio Vender 1985

116

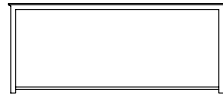

TABLES

Progettato nel 1939 da Mario Asnago e Claudio Vender, il tavolo Moka appartiene alla collezione Flexform dal 1985. Mario Asnago e Claudio Vender iniziano il loro sodalizio professionale negli anni Trenta del Novecento e sono a buon titolo considerati tra i maggiori esponenti del razionalismo italiano.

Come già l'omonima sedia, anche il tavolo Moka presenta una sorprendente modernità ed è ricco di riferimenti e di echi progettuali che rimandano al razionalismo più puro.

La base del tavolo è costituita da un'esile quanto elegante struttura in tubolare metallico disponibile nelle finiture verniciato alluminio, bianco e nero che ben si accorda con l'altrettanto essenziale piano proposto nelle varianti legno o cristallo.

Il disegno puro ed essenziale del tavolo Moka lo colloca tra i prodotti destinati ad attraversare indenni il tempo e le mode.

Designed in 1939 by Mario Asnago and Claudio Vender, the Moka table has been part of the Flexform collection since 1985. Mario Asnago and Claudio Vender commenced their professional partnership in the 1930s and are legitimately considered among the leading exponents of Italian rationalism.

Like its namesake chair, the Moka table is surprisingly modern and dense with design references reminiscent of pure rationalism.

The slender, elegant tubular metal table base comes in painted black, white or aluminum color that is thoroughly compatible with the equally understated top, available in wood or glass.

The pure, uncomplicated design of the Moka table places it among the products sure to remain untouched by fleeting time and fashions.



118



TIPOLOGIE POLTRONCINE/SEDIE/SGABELLI - TAVOLI - LIBRERIE/CONTENITORI/
 COMPLEMENTI **PRODOTTO** TAVOLO **STRUTTURA** IN METALLO VERNICIATO CON
 POLVERI EPOSSIDICHE NEI COLORI BIANCO, NERO, ALLUMINIO. APPOGGIO A TERRA
 SU PUNTALI IN MATERIALE TERMOPLASTICO **PIANO** IN LEGNO IMPIALLACCIATO
 DI NOCE CANALETTO NELLE FINITURE NATURALE, TINTO EXTRA, TINTO CAFFÈ O
 IMPIALLACCIATO DI FRASSINO NELLE FINITURE NATURALE, TINTO NOCE, TINTO
 CILIEGIO, TINTO TEAK, TINTO CAFFÈ, TINTO WENGÉ, TINTO EBANO, TINTO MARRONE
 O IN CRISTALLO NELLE FINITURE TRASPARENTE, ACIDATO

CATEGORIES SMALL ARMCHAIRS/CHAIRS/STOOLS - TABLES - BOOKSHELVES/
 FURNISHINGS/CABINETS **PRODUCT** TABLE **STRUCTURE** IN EPOXY POWDER-
 COATED METAL IN WHITE, BLACK OR ALUMINUM COLOR. RESTS ON PADS MADE OF
 THERMOPLASTIC MATERIAL **TOP** IN CANALETTO WALNUT VENEER WITH NATURAL
 FINISH, OR STAINED CANALETTO WALNUT EXTRA OR COFFEE; OR, IN ASH VENEER
 WITH NATURAL FINISH OR STAINED WALNUT, CHERRY, TEAK, COFFEE, WENGE,
 EBONY OR BROWN; OR, IN GLASS WITH TRANSPARENT OR ACID-ETCHED FINISH

14560

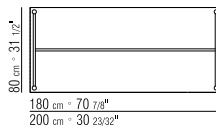
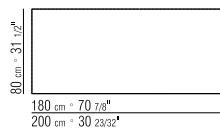
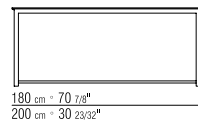
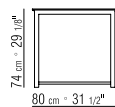
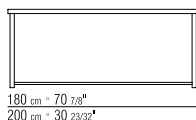
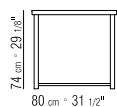

Moka
 Data Sheet

Monreale

Antonio Citterio 2017

120



TABLES

La calda matericità del legno – un materiale vivo ed espressivo come pochi altri – conferisce un carattere forte al tavolo Monreale.

Ogni dettaglio costruttivo del tavolo Monreale rivela la complessità che si cela dietro un'apparente semplicità: le importanti benché essenziali gambe in legno massello sottolineano l'aspetto nobile ed austero che contraddistingue questo tavolo e sono un fine esempio di come la tradizione ebanista possa rivivere in forme contemporanee.

Il rigoroso piano a forte spessore è impiallacciato nelle essenze noce canaletto e frassino, proposti in un'ampia gamma di tinte.

Monreale è un tavolo dalle proporzioni generose che può accomodare fino a dieci commensali.

The warm feel of wood – a vibrant material, expressive like few others – lends the Monreale table an extraordinary personality.

The complexity concealed behind its apparent simplicity is evident in every construction detail of the Monreale table. The substantial though unadorned solid wood legs emphasize the fine natural qualities that distinguish this table and are an exquisite example of how the cabinetmaking tradition can be revisited in a contemporary guise.

The massive, dignified top comes in Canaletto walnut or ash veneer, available in a wide range of stains.

With its generous proportions, the Monreale table can accommodate up to ten diners.



122



TIPOLOGIE TAVOLI **PRODOTTO** TAVOLO **STRUTTURA** IN LEGNO MASSELLO DI NOCE CANALETTO NELLE FINITURE NATURALE, TINTO EXTRA, TINTO CAFFÈ O MASSELLO DI FRASSINO NELLE FINITURE NATURALE, TINTO NOCE, TINTO CILIEGIO, TINTO TEAK, TINTO CAFFÈ, TINTO WENGÉ, TINTO EBANO, TINTO MARRONE **PIANO** IN LEGNO IMPIALLACCIATO DI NOCE CANALETTO NELLE FINITURE NATURALE, TINTO EXTRA, TINTO CAFFÈ O IMPIALLACCIATO DI FRASSINO NELLE FINITURE NATURALE, TINTO NOCE, TINTO CILIEGIO, TINTO TEAK, TINTO CAFFÈ, TINTO WENGÉ, TINTO EBANO, TINTO MARRONE **PIEDE** IN METALLO NELLE FINITURE SATINATO, CROMATO, CROMO NERO, BRUNITO, CHAMPAGNE

CATEGORIES TABLES **PRODUCT** TABLE **STRUCTURE** IN SOLID CANALETTO WALNUT WITH NATURAL FINISH, OR STAINED CANALETTO WALNUT EXTRA OR COFFEE; OR, IN SOLID ASH WITH NATURAL FINISH OR STAINED WALNUT, CHERRY, TEAK, COFFEE, WENGE, EBONY OR BROWN **TOP** IN CANALETTO WALNUT VENEER WITH NATURAL FINISH, OR STAINED CANALETTO WALNUT EXTRA OR COFFEE; OR, IN ASH VENEER WITH NATURAL FINISH OR STAINED WALNUT, CHERRY, TEAK, COFFEE, WENGE, EBONY OR BROWN **FEET** IN METAL WITH SATIN, CHROME, BLACK CHROME, BURNISHED OR CHAMPAGNE FINISH

24082

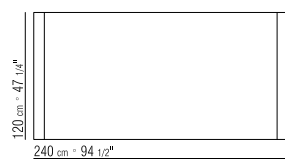
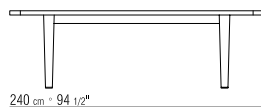
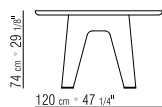

24084

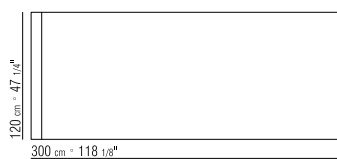
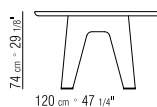

Monreale
Data Sheet

Soffio

Antonio Citterio 2015

124

Soffio è un tavolo che presenta una rigorosa costruzione architettonica. Le gambe in metallo a sezione piatta rappresentano il segno distintivo del progetto. Salgono leggere e disegnano un'originale forma a "boomerang" che rende lo stacco da terra particolarmente dinamico.

Solido ed aereo al contempo, il tavolo Soffio presenta un interessante contrasto tra la leggerezza della base in metallo – disponibile nelle finiture satinato, cromato, brunito, cromo nero e champagne – e l'essenziale piano di forma rettangolare proposto nelle versioni legno canaletto o frassino in varie nuance oppure in pregiato marmo.

Soffio is a table with a rigorous architectural stance.

The flat metal legs are a hallmark feature of the design. Ascending lightly, they design an original "boomerang" shape that sends a dynamic current through the space between the table and the floor.

Solid yet airy, the Soffio table reflects the fascinating contrast between the lightness of the metal base – available in satin, chrome, burnished, black chrome or champagne finish – and the sleek rectangular top, available in Canaletto walnut or ash, stained in a number of colors, or in luxurious marble.



TABLES



SPAIN | IBIZA | PRIVATE VILLA | ZEFIRO TABLE | ISABEL DINING CHAIRS



TIPOLOGIE TAVOLI - TAVOLINI/CONSOLLE **PRODOTTO TAVOLO** **STRUTTURA**
 IN METALLO NELLE FINITURE SATINATO, CROMATO, CROMO NERO, BRUNITO,
 CHAMPAGNE. APPOGGIO A TERRA SU PUNTALI IN MATERIALE TERMOPLASTICO **PIANO**
 TAVOLI IN LEGNO IMPIALLACCIATO DI NOCE CANALETTO NELLE FINITURE NATURALE,
 TINTO EXTRA, TINTO CAFFÈ O MASSELLO DI FRASSINO NELLE FINITURE NATURALE,
 TINTO NOCE, TINTO CILIEGIO, TINTO TEAK, TINTO CAFFÈ, TINTO WENGÉ, TINTO EBANO,
 TINTO MARRONE O IN MARMO NELLE TIPOLOGIE CALACATTA ORO LUCIDO, MARMO
 CALACATTA ORO OPACO, BIANCO CARRARA LUCIDO, NERO MARQUINIA LUCIDO,
 EMPERADOR LUCIDO, EMPERADOR OPACO CON SUPPORTO IN LEGNO MULTISTRATO

CATEGORIES TABLES - COFFEE TABLES/SIDE TABLES/CONSOLES **PRODUCT TABLE**
STRUCTURE IN METAL WITH SATIN, CHROME, BLACK CHROME, BURNISHED OR
 CHAMPAGNE FINISH. RESTS ON PADS MADE OF THERMOPLASTIC MATERIAL **TOP**
 IN CANALETTO VENEER WITH NATURAL FINISH, OR STAINED CANALETTO
 WALNUT EXTRA OR COFFEE; OR, IN SOLID ASH WITH NATURAL FINISH OR STAINED
 WALNUT, CHERRY, TEAK, COFFEE, WENGE, EBONY OR BROWN; OR, IN THE
 FOLLOWING TYPES OF MARBLE: CALACATTA GOLD POLISHED OR MATTE, POLISHED
 WHITE CARRARA, POLISHED BLACK MARQUINA, EMPERADOR POLISHED OR MATTE
 WITH PLYWOOD SUPPORT

22460

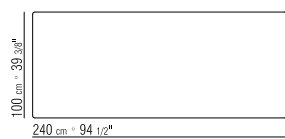
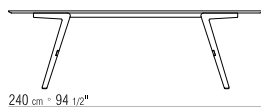
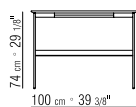

22463

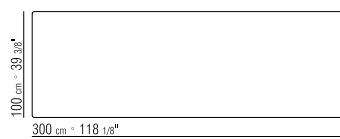
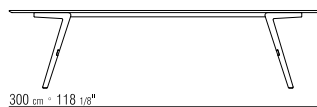
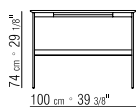

Soffio

Data Sheet

Spello

Gabriele e Oscar Buratti 2018

128

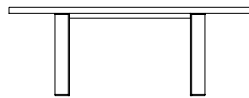

TABLES

Due scultoree basi in metallo verniciato conferiscono al tavolo Spello una marcata personalità. Fonte di ispirazione il brutalismo, corrente architettonica ed artistica caratterizzata da forme aspre e asciutte e strutture robuste.

Alla severità della base d'appoggio, si contrappone la poetica matericità del piano in legno massello, enfatizzata dal disegno delle lastre che ricorda la nobile tradizione dell'intarsio e da una sottile fessura che corre in senso longitudinale al piano.

Il tavolo Spello è disponibile unicamente con piano rettangolare impiallacciato nelle finiture in noce canaletto e frassino, in molteplici tinte. Prevista anche la variante con piano in marmo in molteplici varietà.

The Spello table – two sculptural bases in painted metal – spells unmistakable personality. The source of inspiration is brutalism, an architectural and artistic movement known for its rugged, raw shapes and robust structures.

Contrasting the severity of the support base is the poetic texture of the solid wood top, played up by the design of the boards that echo the noble tradition of inlay work and by a subtle opening that runs the length of the top. Available only in rectangular version, the Spello table comes veneered in Canaletto walnut or ash in a choice of stains. It is also available in a version with an array of marble top choices.



TIPOLOGIE TAVOLI PRODOTTO TAVOLO STRUTTURA IN METALLO VERNICIATA CON POLVERI EPOSSIDICHE NEI COLORI BIANCO 100, BEIGE PERLATO 130, BIANCO CREMA 150, BIANCO OPACO 160, PANNA 205, ROSSO VINO 405, VERDE KAKI 705, GRIGIO OMBRA 720, GRIGIO TOPO PERLATO 740, MARRONE GRIGIO 805, NERO 900 O BRUNITO. APPOGGIO A TERRA SU PUNTALI IN MATERIALE TERMOPLASTICO **PIANO** IN LEGNO IMPIALLACCIATO DI NOCE CANALETTO NELLE FINITURE NATURALE, TINTO EXTRA, TINTO CAFFÈ O MASSELLO DI FRASSINO NELLE FINITURE NATURALE, TINTO NOCE, TINTO CILIEGIO, TINTO TEAK, TINTO CAFFÈ, TINTO WENGÉ, TINTO EBANO, TINTO MARRONE O IN MARMO NELLE TIPOLOGIE CALACATTA ORO LUCIDO, MARMO CALACATTA ORO OPACO, BIANCO CARRARA LUCIDO, NERO MARQUINIA LUCIDO, EMPERADOR LUCIDO, EMPERADOR OPACO CON SUPPORTO IN LEGNO MULTISTRATO

CATEGORIES TABLES PRODUCT TABLE STRUCTURE IN EPOXY-POWDER-COATED METAL IN THE FOLLOWING COLORS: WHITE 100, PEARL BEIGE 130, CREAM-WHITE 150, MATTE WHITE 160, CREAM 205, WINE RED 405, KHAKI GREEN 705, UMBRA GREY 720, PEARL MOUSE GREY 740, GREY BROWN 805, BLACK 900, OR BURNISHED. RESTS ON PADS MADE OF THERMOPLASTIC MATERIAL **TOP** IN CANALETTO WALNUT VENEER WITH NATURAL FINISH, OR STAINED CANALETTO WALNUT EXTRA OR COFFEE; OR, IN SOLID ASH WITH NATURAL FINISH OR STAINED WALNUT, CHERRY, TEAK, COFFEE, WENGE, EBONY OR BROWN; OR, IN THE FOLLOWING TYPES OF MARBLE: CALACATTA GOLD POLISHED OR MATTE, POLISHED WHITE CARRARA, POLISHED BLACK MARQUINA, EMPERADOR POLISHED OR MATTE, WITH PLYWOOD SUPPORT

25280

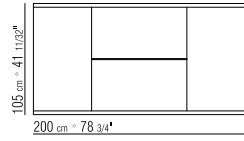
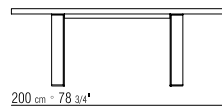
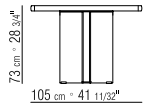

25281

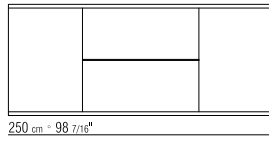
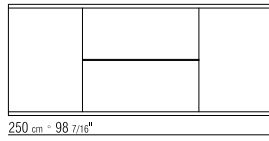
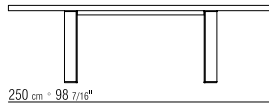

25282

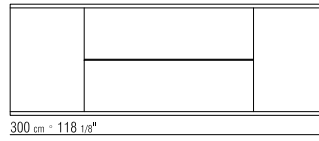
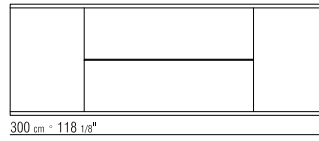
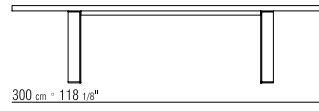

25285

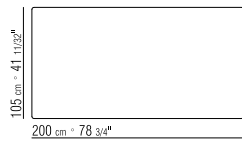
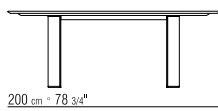
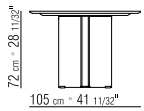

25286

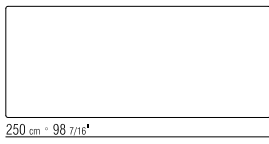
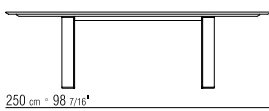
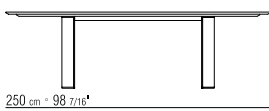

25287

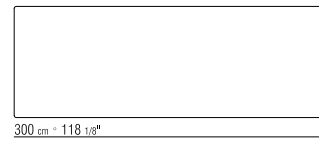
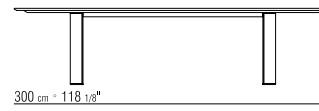
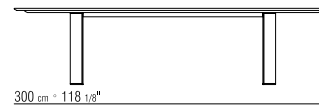

Zefiro

Antonio Citterio 2017 | 2018

132



TABLES

L'ampia collezione di tavoli da pranzo Zefiro è caratterizzata da un segno lieve e contemporaneo.

Zefiro è un tavolo estremamente versatile, grazie all'ampia gamma di misure e materiali con i quali può essere realizzato e che pertanto si presta ad inserirsi con stile ed eleganza in qualsiasi ambiente e a soddisfare le esigenze più diverse.

Le affusolate gambe in alluminio pressofuso disponibili nelle finiture satinato, cromato, brunito, cromo nero, champagne e verniciato nei colori bianco e nero conferiscono leggerezza e dinamicità ai tavoli Zefiro.

I piani sono proposti nelle varianti tondo, quadrato, ovale e rettangolare in una pluralità di misure e possono essere realizzati nelle versioni impiallacciato in noce canaletto o frassino in molteplici tinte, in diverse varietà di pregiato marmo oppure in vetro retro-verniciato in eleganti nuance con un raffinato profilo in metallo.

A light, contemporary spirit defines the extensive collection of Zefiro dining tables.

Extremely versatile, thanks to the wide range of sizes and materials in which it can be crafted, the Zefiro table can confidently and stylishly furnish any setting and meet the most diverse needs.

Available in satin, chrome, burnished, black chrome or champagne finish, or painted black or white, the tapered cast-aluminum legs lend an air of lightness and dynamism to the Zefiro tables.

The tops come in round, square, oval or rectangular shape in a number of different sizes and can be crafted in versions with Canaletto walnut or ash veneer, stained in a number of shades; in various types of luxurious marble; or in back-painted glass in tasteful hues, complete with handsome metal edging.







Extremely versatile thanks to its contemporary spirit and to the wide range of sizes and finishes, the Zefiro table can stylishly furnish any setting.





TIPOLOGIE TAVOLI - TAVOLINI/CONSOLLE **PRODOTTO** TAVOLO **STRUTTURA** IN METALLO ED ALLUMINIO PRESSOFUSO NELLE FINITURE SATINATO, CROMATO, CROMO NERO, BRUNITO, CHAMPAGNE, BIANCO 100, NERO 900. APPOGGIO A TERRA SU PUNTALI IN MATERIALE TERMOPLASTICO **PIANO** IN LEGNO IMPIALLACCIATO DI NOCE CANALETTO NELLE FINITURE NATURALE, TINTO EXTRA, TINTO CAFFÈ O IMPIALLACCIATO DI FRASSINO NELLE FINITURE NATURALE, TINTO NOCE, TINTO CILIEGIO, TINTO TEAK, TINTO CAFFÈ, TINTO WENGÉ, TINTO EBANO, TINTO MARRONE O IN LEGNO LACCATO LUCIDO NEI COLORI BIANCO, NERO, LILLA, GRIGIO VERDE, MOKA, SALMONE, TORTORA, VERDE PINO O IN MARMO NELLE TIPOLOGIE CALACATTA ORO LUCIDO, MARMO CALACATTA ORO OPACO, BIANCO CARRARA LUCIDO, NERO MARQUINIA LUCIDO, EMPERADOR LUCIDO, EMPERADOR OPACO O IN METALLO CON PIANO IN VETRO RETROVERNICIATO NEI COLORI BIANCO SETA, CAFFÈ, GRIGIO, NERO, CON SUPPORTO IN LEGNO MULTISTRATO. LA VERSIONE MARMO NON È DISPONIBILE PER TAVOLI CON PIANO ROTONDO. LA VERSIONE IN VETRO NON È DISPONIBILE PER TAVOLI CON PIANO OVALE

CATEGORIES TABLES - COFFEE TABLES/SIDE TABLES/CONSOLES **PRODUCT** TABLE **STRUCTURE** IN METAL AND CAST ALUMINUM WITH SATIN, CHROME, BLACK CHROME, BURNISHED, CHAMPAGNE, WHITE 100 OR BLACK 900 FINISH. RESTS ON PADS MADE OF THERMOPLASTIC MATERIAL **TOP** IN CANALETTO WALNUT VENEER WITH NATURAL FINISH, OR STAINED CANALETTO WALNUT EXTRA OR COFFEE; OR, IN ASH VENEER WITH NATURAL FINISH OR STAINED WALNUT, CHERRY, TEAK, COFFEE, WENGE, EBONY OR BROWN; OR IN WOOD WITH GLOSSY LACQUER FINISH IN WHITE, BLACK, LILAC, GREY-GREEN, MOCHA, SALMON, DOVE GREY OR PINE GREEN; OR, IN THE FOLLOWING TYPES OF MARBLE: CALACATTA GOLD POLISHED OR MATTE, POLISHED WHITE CARRARA, POLISHED BLACK MARQUINA, EMPERADOR POLISHED OR MATTE; OR, IN METAL WITH TOP IN BACKPAINTED GLASS IN THE FOLLOWING COLORS: SILK WHITE, COFFEE, GREY OR BLACK, WITH PLYWOOD SUPPORT. THE MARBLE VERSION IS NOT AVAILABLE FOR TABLES WITH ROUND TOP. THE GLASS VERSION IS NOT AVAILABLE FOR TABLES WITH OVAL TOP.

23880

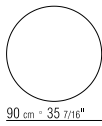
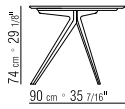

23881

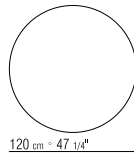
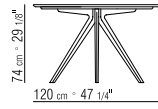

23882

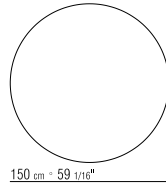
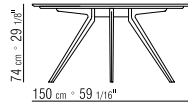

23885

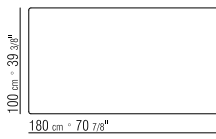
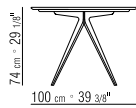

23886

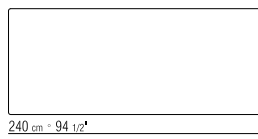
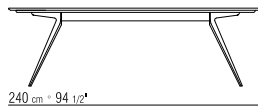

23887

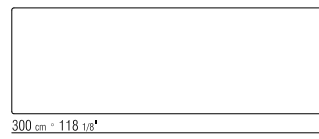
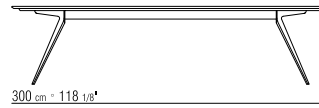

23888

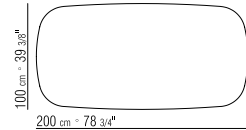
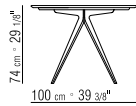

23889

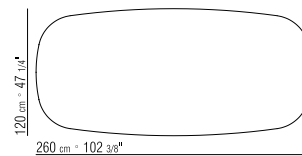
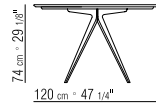

Tavolini Console

Coffee tables | Side tables | Consoles

| | |
|-------------|-----|
| ASCANIO | 142 |
| BRIG | 146 |
| CABARÉ | 150 |
| CARLOTTA | 154 |
| CESTONE | 158 |
| CLARKE | 162 |
| DIDA | 166 |
| ESTE | 170 |
| FLY | 176 |
| GIANO | 184 |
| GIPSY | 188 |
| GROUNDPIECE | 192 |
| GUSTAV | 198 |
| INFINITY | 202 |
| JIFF | 208 |
| KIDD | 212 |
| OLIVER | 216 |
| PLAIN | 220 |
| SOFFIO | 224 |
| SVEVA | 230 |
| TINDARI | 234 |
| TRIS | 238 |
| VIENNA | 242 |
| ZEFIRO | 246 |



Ascanio

Antonio Citterio 2018

142



COFFEE TABLES
SIDE TABLES
CONSOLES

Ascanio è un tavolino in legno massello che unisce alla praticità di utilizzo l'attitudine ad inserirsi con misurata eleganza in qualsiasi ambiente.

La struttura in legno consente di spostarlo agilmente all'interno dello spazio living, per poterlo avvicinare al divano o alla poltrona.

Presenta una varietà di raffinate combinazioni materiche tra la struttura che è proposta in massello di noce canaletto o massello di frassino in una pluralità di colorazioni ed il piano che può essere realizzato anch'esso in legno oppure in marmo, nelle varietà Bianco Carrara, Nero Marquina, Calacatta Oro ed Emperador. Il tavolino Ascanio è disponibile in tre misure.

Ascanio is a solid wood occasional table that not only serves a practical function but also lends an air of discreet elegance to any room.

The table's solid wood structure makes it easy to move around in the living room, for placement near the sofa or an armchair.

A number of tasteful combinations of materials are possible - between the structure in solid Canaletto walnut or solid ash in an array of colors - and the top available in either wood or in several kinds of marble: White Carrara, Black Marquina, Calacatta Gold and Emperador. The Ascanio occasional table is available in three sizes.



TIPOLOGIE TAVOLINI/CONSOLLE **PRODOTTO** TAVOLINO **STRUTTURA** IN LEGNO MASSELLO DI NOCE CANALETTO NELLE FINITURE NATURALE, TINTO EXTRA, TINTO CAFFÈ O MASSELLO DI FRASSINO NELLE FINITURE NATURALE, TINTO NOCE, TINTO CILIEGIO, TINTO TEAK, TINTO CAFFÈ, TINTO WENGÉ, TINTO EBANO, TINTO MARRONE. APPOGGIO A TERRA SU PUNTALI IN MATERIALE TERMOPLASTICO **PIANO** IN LEGNO MASSELLO DI NOCE CANALETTO NELLE FINITURE NATURALE, TINTO EXTRA, TINTO CAFFÈ O DI FRASSINO NELLE FINITURE NATURALE, TINTO NOCE, TINTO CILIEGIO, TINTO TEAK, TINTO CAFFÈ, TINTO WENGÉ, TINTO EBANO, TINTO MARRONE O IN MARMO NELLE TIPOLOGIE CALACATTA ORO LUCIDO, MARMO CALACATTA ORO OPACO, BIANCO CARRARA LUCIDO, NERO MARQUINIA LUCIDO, EMPERADOR LUCIDO, EMPERADOR OPACO

CATEGORIES COFFEE TABLES/SIDE TABLES/CONSOLES **PRODUCT** COFFEE TABLE - SIDE TABLE **STRUCTURE** IN SOLID CANALETTO WALNUT WITH NATURAL FINISH, OR STAINED CANALETTO WALNUT EXTRA OR COFFEE; OR, IN SOLID ASH WITH NATURAL FINISH OR STAINED WALNUT, CHERRY, TEAK, COFFEE, WENGE, EBONY OR BROWN. RESTS ON PADS MADE OF THERMOPLASTIC MATERIAL **TOP** IN SOLID CANALETTO WALNUT WITH NATURAL FINISH, OR STAINED CANALETTO WALNUT EXTRA OR COFFEE; OR, IN ASH WITH NATURAL FINISH OR STAINED WALNUT, CHERRY, TEAK, COFFEE, WENGE, EBONY OR BROWN; OR, IN THE FOLLOWING TYPES OF MARBLE: CALACATTA GOLD POLISHED OR MATTE, POLISHED WHITE CARRARA, POLISHED BLACK MARQUINA, EMPERADOR POLISHED OR MATTE



25070

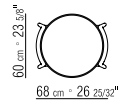
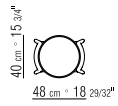
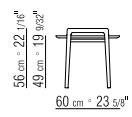
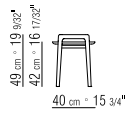

25072

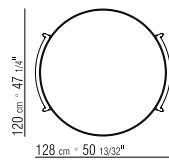
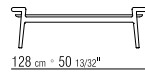
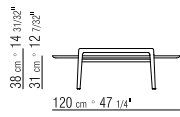

Brig è una famiglia di tavolini e consolle, il cui concept nasce dal desiderio di valorizzare le caratteristiche di un materiale caldo e vivo come il legno, espressivo come pochi altri.

La base del tavolino Brig presenta linee pure e finemente lavorate che valorizzano tutto il pregio del legno massello. Due le essenze utilizzate: noce canaletto e frassino, proposte in una varietà di eleganti nuance.

La versione monomaterica del tavolino Brig prevede che il piano venga realizzato nella medesima essenza della base, ma esiste anche l'opzione di associare alla struttura in legno un piano in marmo dal bordo smussato, nelle varianti Calacatta Oro, Emperador, Nero Marquina e Bianco Carrara.

A quest to leverage the highly expressive characteristics of a warm, vibrant material like wood led to the design concept behind the Brig family of coffee tables, side tables and consoles.

All the virtues of solid wood are maximized in the pure, finely-crafted lines expressed in the base of the Brig coffee table. It comes in two types of wood – Canaletto walnut or ash – stained in a number of elegant shades.

The Brig coffee table can be crafted with the table top in the same wood as the base. But the wood structure can also be paired with a beveled-edge marble top in the following types of marble: Calacatta Gold, Emperador, Black Marquina or White Carrara.



**COFFEE TABLES
SIDE TABLES
CONSOLES**



TIPOLOGIE TAVOLINI/CONSOLLE **PRODOTTO** TAVOLINO - CONSOLLE **STRUTTURA** IN LEGNO MASSELLO DI NOCE CANALETTO NELLE FINITURE NATURALE, TINTO EXTRA, TINTO CAFFÈ O MASSELLO DI FRASSINO NELLE FINITURE NATURALE, TINTO NOCE, TINTO CILIEGIO, TINTO TEAK, TINTO CAFFÈ, TINTO WENGÉ, TINTO EBANO, TINTO MARRONE. APPOGGIO A TERRA SU PUNTALI IN MATERIALE TERMOPLASTICO **PIANO** IN LEGNO MASSELLO DI NOCE CANALETTO NELLE FINITURE NATURALE, TINTO EXTRA, TINTO CAFFÈ O MASSELLO DI FRASSINO NELLE FINITURE NATURALE, TINTO NOCE, TINTO CILIEGIO, TINTO TEAK, TINTO CAFFÈ, TINTO WENGÉ, TINTO EBANO, TINTO MARRONE. DISPONIBILE ANCHE IN MARMO NELLE TIPOLOGIE CALACATTA ORO LUCIDO, MARMO CALACATTA ORO OPACO, BIANCO CARRARA LUCIDO, NERO MARQUINIA LUCIDO, EMPERADOR LUCIDO, EMPERADOR OPACO

CATEGORIES ARMCHAIRS/OTTOMANS - COFFEE TABLES/SIDE TABLES/CONSOLES **PRODUCT** SMALL TABLE - CONSOLE **STRUCTURE** IN SOLID CANALETTO WALNUT WITH NATURAL FINISH, OR STAINED CANALETTO WALNUT EXTRA OR COFFEE; OR, IN SOLID ASH WITH NATURAL FINISH OR STAINED WALNUT, CHERRY, TEAK, COFFEE, WENGE, EBONY OR BROWN. RESTS ON PADS MADE OF THERMOPLASTIC MATERIAL **TOP** IN SOLID CANALETTO WALNUT WITH NATURAL FINISH, OR STAINED CANALETTO WALNUT EXTRA OR COFFEE; OR, IN SOLID ASH WITH NATURAL FINISH OR STAINED WALNUT, CHERRY, TEAK, COFFEE, WENGE, EBONY OR BROWN. ALSO AVAILABLE IN THE FOLLOWING TYPES OF MARBLE: CALACATTA GOLD POLISHED OR MATTE, POLISHED WHITE CARRARA, POLISHED BLACK MARQUINA, EMPERADOR POLISHED OR MATTE



23260

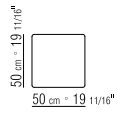
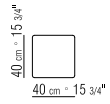
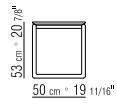
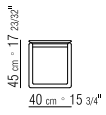

23261

23264

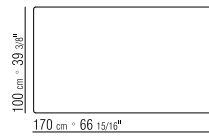
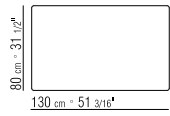
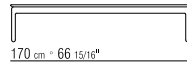
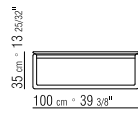
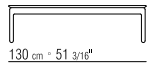
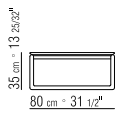

23265

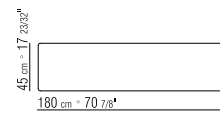
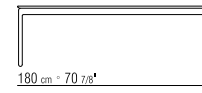
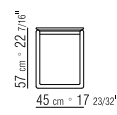

23268

Cabaré

Design Center 2017

150

Elegante quanto funzionale, Cabaré è un tavolino che si presta ad essere accostato a tutte le sedute della collezione Flexform.

Di forma tonda, presenta una raffinata struttura in legno massello – noce canaletto o frassino proposti in una varietà di finiture – e due piani sovrapposti in metallo rivestito in cuoio: quello inferiore può rivelarsi utile per appoggiare libri o riviste; il piano superiore è sormontato da un pratico vassoio asportabile, da cui il tavolino Cabaré prende il nome. Il vassoio è realizzato in metallo nelle finiture satinato, cromato, brunito, cromo nero e champagne, e fa di Cabaré un autentico jolly all'interno dello spazio living.

As elegant as it is functional, Cabaré is a side table that fits serenely alongside any of the seating options in the Flexform collection.

It has a sophisticated round solid-wood structure – in Canaletto walnut or ash, available in an array of finishes – and two stacked tops in cowhide-clad metal – the lower one can serve as a handy place for books or magazines; the upper top also comes with a removable tray, from which the Cabaré side table derives its name.

The metal tray comes in satin, chrome, burnished, black chrome or champagne finish, making Cabaré an authentic multipurpose piece.



**COFFEE TABLES
SIDE TABLES
CONSOLES**





TIPOLOGIE TAVOLINI/CONSOLLE **PRODOTTO** TAVOLINO **STRUTTURA** IN LEGNO MASSELLO DI NOCE CANALETTO NELLE FINITURE NATURALE, TINTO EXTRA, TINTO CAFFÈ O MASSELLO DI FRASSINO NELLE FINITURE NATURALE, TINTO NOCE, TINTO CILIEGIO, TINTO TEAK, TINTO CAFFÈ, TINTO WENGÉ, TINTO EBANO, TINTO MARRONE. APPOGGIO A TERRA SU PUNTALI IN MATERIALE TERMOPLASTICO **PIANO** IN METALLO RIVESTITO IN CUIOIO NEI COLORI BIANCO 5007, GRIGIO 5003, TESTA DI MORO 5004, TESTA DI MORO SCURO 5013, NERO 5005, OLIVA 5006, ROSSO BULGARO 5008, SABBIA 5001, TABACCO 5015. VASSOIO ASPORTABILE IN METALLO NELLE FINITURE SATINATO, CROMATO, CROMO NERO, BRUNITO, CHAMPAGNE

CATEGORIES COFFEE TABLES/SIDE TABLES/CONSOLES **PRODUCT** COFFEE TABLE **STRUCTURE** IN SOLID CANALETTO WALNUT WITH NATURAL FINISH, OR STAINED CANALETTO WALNUT EXTRA OR COFFEE; OR, IN SOLID ASH WITH NATURAL FINISH OR STAINED WALNUT, CHERRY, TEAK, COFFEE, WENGE, EBONY OR BROWN. RESTS ON PADS MADE OF THERMOPLASTIC MATERIAL **TOP** IN METAL CLAD IN COWHIDE IN THE FOLLOWING COLORS: WHITE 5007, GREY 5003, DARK BROWN 5004, EXTRA DARK BROWN 5013, BLACK 5005, OLIVE 5006, BULGARIAN RED 5008, SAND 5001 OR TOBACCO 5015. REMOVABLE TRAY IN METAL WITH SATIN, CHROME, BLACK CHROME, BURNISHED OR CHAMPAGNE FINISH

23970



Cabaré Data Sheet

Carlotta

Antonio Citterio 1997

154

**COFFEE TABLES
SIDE TABLES
CONSOLES**



Un funzionale tavolino caratterizzato da un segno intramontabile, la cui matrice progettuale è ispirata alla scuola del Bauhaus.

La struttura in metallo, proposta nelle finiture cromato, satinato, brunito, cromo nero e champagne, reca in evidenza le viti nei punti di giuntura a rimarcare il disegno rigoroso ed essenziale che caratterizza questo tavolino.

I piani di appoggio – due nella versione tonda ed uno nel tavolino quadrato – possono essere realizzati in noce canaletto e frassino tinti in un'ampia gamma cromatica oppure laccati in una palette di toni raffinati.

The timeless design of this practical side table has its roots in the Bauhaus school.

The joint screws, clearly visible on the metal structure, emphasize the austere, unornamented design that sets this side table apart. It comes in chrome, satin, burnished, black chrome or champagne finish.

Three table tops – two in the round version and one square – can be crafted in Canaletto walnut or ash, stained in a wide palette of colors or lacquered in an array of sophisticated shades.



156



TIPOLOGIE POLTRONE/POUF - TAVOLINI/CONSOLLE **PRODOTTO** TAVOLINO **STRUTTURA** IN METALLO NELLE FINITURE SATINATO, CROMATO, CROMO NERO, BRUNITO, CHAMPAGNE. APPOGGIO A TERRA SU PUNTALI IN MATERIALE TERMOPLASTICO **PIANO** IN LEGNO LACCATO CON VERNICE ANTIGRAFFIO AD ALTA RESISTENZA NEI COLORI BIANCO 102, NERO 902; IN LEGNO IMPIALLACCIATO DI NOCE CANALETTO NELLE FINITURE NATURALE, TINTO EXTRA, TINTO CAFFÈ; IMPIALLACCIATO DI FRASSINO NELLE FINITURE NATURALE, TINTO NOCE, TINTO CILIEGIO, TINTO TEAK, TINTO CAFFÈ, TINTO WENGÉ, TINTO EBANO, TINTO MARRONE; O IN LEGNO LACCATO LUCIDO NEI COLORI BIANCO, NERO, LILLA, GRIGIO VERDE, MOKA, SALMONE, TORTORA, VERDE PINO

CATEGORIES ARMCHAIR/OTTOMANS - COFFEE TABLES/SIDE TABLES/CONSOLES **PRODUCT** SMALL TABLE **STRUCTURE** IN METAL WITH SATIN, CHROME, BLACK CHROME, BURNISHED OR CHAMPAGNE FINISH. RESTS ON PADS MADE OF THERMOPLASTIC MATERIAL **TOP** IN WOOD LACQUERED WITH HIGHLY SCRATCH-RESISTANT PAINT IN WHITE 102 OR BLACK 902; IN CANALETTO WALNUT VENEER IN THE FOLLOWING FINISHES: NATURAL, OR STAINED CANALETTO WALNUT EXTRA OR COFFEE; OR, IN ASH VENEER WITH NATURAL FINISH OR STAINED WALNUT, CHERRY, TEAK, COFFEE, WENGE, EBONY OR BROWN; OR, IN WOOD WITH GLOSSY LACQUER FINISH IN WHITE, BLACK, LILAC, GREY-GREEN, MOCHA, SALMON, DOVE GREY OR PINE GREEN

13U70

13U74

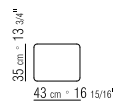
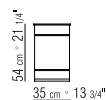
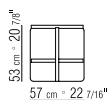

Cestone

Antonio Citterio 2011

158

**COFFEE TABLES
SIDE TABLES
CONSOLES**



Appositamente progettati quali elementi di servizio all'omonimo divano, i tavolini e le consolle Cestone assolvono alla funzione di pratici piani d'appoggio e contribuiscono a rendere ancora più dinamiche le composizioni.

L'esile base è in metallo disponibile nelle finiture satinato, cromato, brunito, cromo nero e champagne, mentre i piani sagomati possono essere realizzati in noce canaletto e frassino tinti in un'ampia gamma cromatica oppure laccati in una palette di toni raffinati.

The Cestone side tables and consoles, purposely designed as complements to the eponymous sofa, serve as handy table-top surfaces, lending a decidedly dynamic feel to any composition.

The slender metal base comes in satin, chrome, burnished, black chrome or champagne finish, while the contoured tops can be crafted in Canaletto walnut or ash, stained in a wide palette of colors or lacquered in an array of sophisticated shades.



160



TIPOLOGIE DIVANI/DIVANI COMPONENTI/POUF - TAVOLINI/CONSOLLE **PRODOTTO** TAVOLINO - CONSOLLE **STRUTTURA** IN METALLO NELLE FINITURE SATINATO, CROMATO, CROMO NERO, BRUNITO, CHAMPAGNE. APPOGGIO A TERRA SU PUNTALI IN MATERIALE TERMOPLASTICO **PIANO** IN LEGNO MASSELLO DI NOCE CANALETTO NELLE FINITURE NATURALE, TINTO EXTRA, TINTO CAFFÈ O MASSELLO DI FRASSINO NELLE FINITURE NATURALE, TINTO NOCE, TINTO CILIEGIO, TINTO TEAK, TINTO CAFFÈ, TINTO WENGÉ, TINTO EBANO, TINTO MARRONE O IN LEGNO LACCATO LUCIDO NELLE FINITURE BIANCO, NERO, LILLA, GRIGIO VERDE, MOKA, SALMONE, TORTORA, VERDE PINO

CATEGORIES SOFAS/SECTIONAL SOFAS/OTTOMANS - COFFEE TABLES/SIDE TABLES/CONSOLES **PRODUCT** CONSOLE **STRUCTURE** IN METAL WITH SATIN, CHROME, BLACK CHROME, BURNISHED OR CHAMPAGNE FINISH. RESTS ON PADS MADE OF THERMOPLASTIC MATERIAL **TOP** IN SOLID CANALETTO WALNUT WITH NATURAL FINISH, OR STAINED CANALETTO WALNUT EXTRA OR COFFEE; OR, IN ASH WITH NATURAL FINISH OR STAINED WALNUT, CHERRY, TEAK, COFFEE, WENGE, EBONY OR BROWN; OR IN WOOD WITH GLOSSY LACQUER FINISH IN WHITE, BLACK, LILAC, GREY-GREEN, MOCHA, SALMON, DOVE GREY OR PINE GREEN

14L91

14L92

14L94

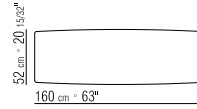
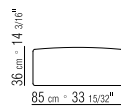
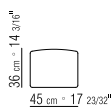
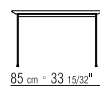

Cestone

Data Sheet

**COFFEE TABLES
SIDE TABLES
CONSOLES**



Il tavolino Clarke è caratterizzato da una sofisticata struttura in metallo che costituisce sia la cornice sopra la quale viene collocato il piano in legno o marmo, sia la base del tavolino, contraddistinta da un elegante disegno delle barre di raccordo delle gambe.

Alla linea essenziale del disegno si accompagna la scelta di materie di forte impatto scenico e di grande pregio: la base in metallo è proposta nelle finiture satinato, cromato, brunito, cromo nero e champagne; mentre il piano in marmo può essere realizzato nelle versioni Calacatta Oro, Emperador, Nero Marquina, Bianco Carrara oppure in massello di noce canaletto o frassino, in un'ampia gamma di tinte.

The Clarke coffee table's metal structure forms both the frame upon which the wood or marble top rests and the base of the table, where the bars that join the legs create an exquisitely understated contemporary design.

The table's sleek lines are complemented by the choice of boldly dramatic and luxurious materials – the metal base comes in satin, chrome, burnished, black chrome or champagne finish, while the marble top can be crafted in Calacatta Gold, Emperador, Black Marquina or White Carrara marble, or in solid Canaletto walnut or ash, stained in an array of colors.



164



TIPOLOGIE TAVOLI - TAVOLINI/CONSOLLE **PRODOTTO TAVOLINO STRUTTURA**
 IN METALLO NELLE FINITURE SATINATO, CROMATO, CROMO NERO, BRUNITO,
 CHAMPAGNE. APPOGGIO A TERRA SU PUNTALI IN MATERIALE TERMOPLASTICO
PIANO IN LEGNO MASSELLO DI FRASSINO NELLE FINITURE NATURALE, TINTO
 NOCE, TINTO CILIEGIO, TINTO TEAK, TINTO CAFFÈ, TINTO WENGÉ, TINTO EBANO,
 TINTO MARRONE O IN MARMO NELLE TIPOLOGIE CALACATTA ORO LUCIDO, MARMO
 CALACATTA ORO OPACO, BIANCO CARRARA LUCIDO, NERO MARQUINIA LUCIDO,
 EMPERADOR LUCIDO, EMPERADOR OPACO

CATEGORIES TABLES - COFFEE TABLES/SIDE TABLES/CONSOLES **PRODUCT COFFEE**
TABLE - SIDE TABLE **STRUCTURE** IN METAL WITH SATIN, CHROME, BLACK CHROME,
 BURNISHED OR CHAMPAGNE FINISH. RESTS ON PADS MADE OF THERMOPLASTIC
 MATERIAL **TOP** IN SOLID ASH WITH NATURAL FINISH OR STAINED WALNUT, CHERRY,
 TEAK, COFFEE, WENGE, EBONY OR BROWN; OR, IN THE FOLLOWING TYPES OF
 MARBLE: CALACATTA GOLD POLISHED OR MATTE, POLISHED WHITE CARRARA,
 POLISHED BLACK MARQUINA, EMPERADOR POLISHED OR MATTE

15W60

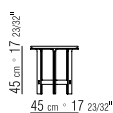

15W61

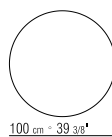
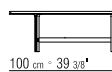
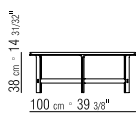

Clarke

Data Sheet

**COFFEE TABLES
SIDE TABLES
CONSOLES**

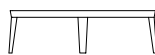

Chiari riferimenti alla tradizione ebanista per i tavolini Dida, seppure rivisitata in chiave contemporanea.

Le gambe in legno massello caratterizzate da una sezione rastremata sostengono il piano in marmo, incastonato come una pietra preziosa dentro una cornice anch'essa in legno massello dal forte spessore e con bordo smussato.

La matericità del legno di frassino tinto in una pluralità di finiture incontra la raffinatezza del marmo, proposto nelle varianti Calacatta Oro, Emperador, Nero Marquinia e Bianco Carrara.

Il tavolo Dida è proposto in tre misure che ne amplificano la versatilità e ne consentono l'inserimento negli ambienti più diversi in abbinamento a tutte le sedute della collezione Flexform.

Though updated with a contemporary edge, the Dida coffee and side tables clearly display their heritage of fine cabinetry tradition.

The marble table top, inset like a precious jewel in the table's substantial solid wood beveled frame, is supported on tapered solid-wood legs.

The physicality of the ash wood, stained in any number of finishes, blends charmingly with the refinement of the marble top, available in Calacatta Gold, Emperador, Black Marquina or White Carrara.

The Dida table comes in three sizes that add to its versatility and allow it to fit comfortably in the most diverse settings, especially when paired with any of the seating elements from the Flexform collection.



168



TIPOLOGIE TAVOLI - TAVOLINI/CONSOLLE **PRODOTTO** TAVOLINO **STRUTTURA** IN LEGNO MASSELLO DI FRASSINO NELLE FINITURE NATURALE, TINTO NOCE, TINTO CILIEGIO, TINTO TEAK, TINTO CAFFÈ, TINTO WENGÉ, TINTO EBANO, TINTO MARRONE. APPOGGIO A TERRA SU PUNTALI IN MATERIALE TERMOPLASTICO **PIANO** IN MARMO NELLE TIPOLOGIE CALACATTA ORO LUCIDO, MARMO CALACATTA ORO OPACO, BIANCO CARRARA LUCIDO, NERO MARQUINIA LUCIDO, EMPERADOR LUCIDO, EMPERADOR OPACO

CATEGORIES TABLES - COFFEE TABLES/SIDE TABLES/CONSOLES **PRODUCT** COFFEE TABLE - SIDE TABLE **STRUCTURE** IN SOLID ASH WITH NATURAL FINISH OR STAINED WALNUT, CHERRY, TEAK, COFFEE, WENGE, EBONY OR BROWN. RESTS ON PADS MADE OF THERMOPLASTIC MATERIAL **TOP** IN THE FOLLOWING TYPES OF MARBLE: CALACATTA GOLD POLISHED OR MATTE, POLISHED WHITE CARRARA, POLISHED BLACK MARQUINA, EMPERADOR POLISHED OR MATTE

14Z60

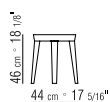

14Z61

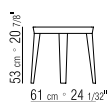

14Z62

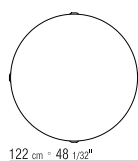
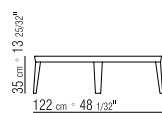

Dida

Data Sheet



**COFFEE TABLES
SIDE TABLES
CONSOLES**

La famiglia di tavolini Este, in origine progettata quale ideale complemento a omonimi divani, rivela in realtà una spiccata personalità che consente a questi tavolini di accompagnarsi con stile ed eleganza a tutte le sedute della collezione Flexform.

Al disegno puro ed essenziale fa da contrappunto la scelta di materiali sofisticati. Le basi riprendono il disegno di quelle dei divani e sono realizzate in metallo nelle finiture satinato, cromato, brunito, cromo nero e champagne. I piani sono proposti nelle versioni in essenza – noce canaletto o frassino tinti in una pluralità di raffinate nuance – laccati in un'originale palette cromatica oppure in marmi di pregio quali Calacatta Oro, Emperador, Nero Marquina e Bianco Carrara.

Originally designed as the ideal complement to the eponymous sofas, the Este family of coffee and side tables reveals a powerful personality that allows these tables to become elegant, stylish complements to all of the seating elements in the Flexform collection.

The choice of sophisticated materials contrasts elegantly with the pure, uncluttered lines of the design. The bases echo the design of the sofa bases and are made of metal with satin, chrome, burnished, black chrome or champagne finish. The tops come in wood – Canaletto walnut or ash, stained in a wide palette of colors; lacquered in a unique array of sophisticated shades; or in premium Calacatta Gold, Emperador, Black Marquina or White Carrara marble.



172

The combination of sophisticated materials – metal, marble, wood and lacquer – contrasts beautifully with the uncluttered lines of the essential design displayed by the Este coffee table.





TIPOLOGIE DIVANI/DIVANI componibili/POUF - TAVOLINI/CONSOLLE **PRODOTTO** TAVOLINO **PIANO** IN LEGNO MASSELLO DI NOCE CANALETTO NELLE FINITURE NATURALE, TINTO EXTRA, TINTO CAFFÈ; O MASSELLO DI FRASSINO NELLE FINITURE NATURALE, TINTO NOCE, TINTO CILIEGIO, TINTO TEAK, TINTO CAFFÈ, TINTO WENGÉ, TINTO EBANO, TINTO MARRONE; O IN LEGNO LACCATO NELLE FINITURE BIANCO, NERO, LILLA, GRIGIO VERDE, MOKA, SALMONE, TORTORA, VERDE PINO; O IN MARMO NELLE TIPOLOGIE CALACATTA ORO LUCIDO, MARMO CALACATTA ORO OPACO, BIANCO CARRARA LUCIDO, NERO MARQUINIA LUCIDO, EMPERADOR LUCIDO, EMPERADOR OPACO CON PANNELLO DI SUPPORTO IN LEGNO MULTISTRATO **PIEDI** IN ALLUMINIO PRESSOFUSO NELLE FINITURE SATINATO, CROMATO, CROMO NERO, BRUNITO, CHAMPAGNE. APPOGGIO A TERRA SU PUNTALI IN MATERIALE TERMOPLASTICO (TAVOLINI CON PIANO IN LEGNO H.33 CM, CON PIANO IN MARMO H.35 CM)

CATEGORIES SOFAS/SECTIONAL SOFAS/OTTOMANS - COFFEE TABLES/SIDE TABLES/ CONSOLES **PRODUCT** COFFEE TABLE **TOP** IN SOLID CANALETTO WALNUT WITH NATURAL FINISH, OR STAINED CANALETTO WALNUT EXTRA OR COFFEE; OR, IN SOLID ASH WITH NATURAL FINISH OR STAINED WALNUT, CHERRY, TEAK, COFFEE, WENGE, EBONY OR BROWN; OR IN WOOD WITH GLOSSY LACQUER FINISH IN WHITE, BLACK, LILAC, GREY-GREEN, MOCHA, SALMON, DOVE GREY OR PINE GREEN; OR, CALACATTA GOLD POLISHED OR MATTE, POLISHED WHITE CARRARA, POLISHED BLACK MARQUINA, EMPERADOR POLISHED OR MATTE, WITH PLYWOOD SUPPORT PANEL **FEET** IN CAST ALUMINUM WITH SATIN, CHROME, BLACK CHROME, BURNISHED OR CHAMPAGNE FINISH. RESTS ON PADS MADE OF THERMOPLASTIC MATERIAL (COFFEE TABLES WITH WOOD TOP H.33CM; WITH MARBLE TOP H. 35CM)

23572

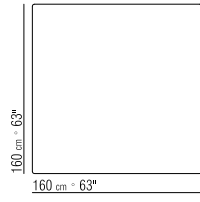
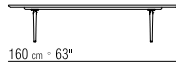
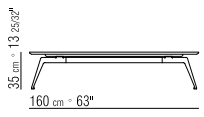

23574

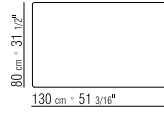
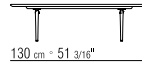
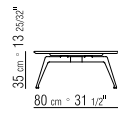

23575

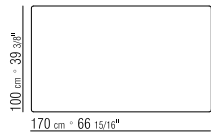
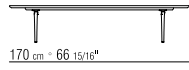
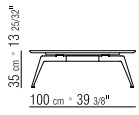

23579

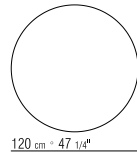
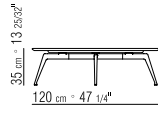

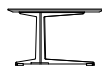

**COFFEE TABLES
SIDE TABLES
CONSOLES**

Un'ampia famiglia di tavoli, tavolini e contenitori caratterizzata da una grande trasversalità, autentica espressione di quel "good design" al quale è improntata tutta la collezione Flexform.

La purezza del disegno unita ad una grande praticità, la varietà di finiture e misure disponibili fanno dei tavolini Fly dei prodotti estremamente versatili.

L'originale base dei tavolini Fly è realizzata in metallo nelle finiture satinato, cromato, brunito, cromo nero e champagne mentre il piano – proposto nelle varianti tondo, ovale, quadrato e rettangolare in una pluralità di misure – è previsto nelle finiture noce canaletto e frassino tinti in molteplici nuance oppure in diverse varietà di marmo.

An extensive family of extremely versatile tables, coffee tables, side tables and cabinets, Fly is a genuine expression of the kind of "good design" upon which the entire Flexform collection is built.

Purity of design, along with amazing practicality and the variety of finishes and sizes available, make Fly products synonymous with extreme versatility.

The unique metal base of the Fly tables comes in chrome, burnished, black chrome or champagne finish, while the top – available in round, oval, square and rectangular shapes, in a number of different sizes – comes in Canaletto walnut or ash, stained in a number of shades, or in various types of marble.



178





180





TIPOLOGIE TAVOLI - TAVOLINI/CONSOLLE - LIBRERIE/COMPLEMENTI/CONTENITORI
PRODOTTO TAVOLINO - CONSOLLE **STRUTTURA** IN METALLO NELLE FINITURE SATINATO, CROMATO, CROMO NERO, BRUNITO, CHAMPAGNE. APPOGGIO A TERRA SU PUNTALI IN MATERIALE TERMOPLASTICO **PIANO ART. 14X60-14X61-14X62-14X69-14X64-14X65-14X68** IN LEGNO MASSELLO DI NOCE CANALETTO NELLE FINITURE NATURALE, TINTO EXTRA, TINTO CAFFÈ; O MASSELLO DI FRASSINO NELLE FINITURE NATURALE, TINTO NOCE, TINTO CILIEGIO, TINTO TEAK, TINTO CAFFÈ, TINTO WENGÉ, TINTO EBANO, TINTO MARRONE; O IN LEGNO LACCATO LUCIDO NELLE FINITURE BIANCO, NERO, LILLA, GRIGIO VERDE, MOKA, SALMONE, TORTORA, VERDE PINO; O IN MARMO NELLE TIPOLOGIE CALACATTA ORO LUCIDO, MARMO CALACATTA ORO OPACO, BIANCO CARRARA LUCIDO, NERO MARQUINIA LUCIDO, EMPERADOR LUCIDO, EMPERADOR OPACO **PIANO ART. 14X50-14X51-14X66** IN LEGNO MASSELLO DI NOCE CANALETTO NELLE FINITURE NATURALE, TINTO EXTRA, TINTO CAFFÈ O MASSELLO DI FRASSINO NELLE FINITURE NATURALE, TINTO NOCE, TINTO CILIEGIO, TINTO TEAK, TINTO CAFFÈ, TINTO WENGÉ, TINTO EBANO, TINTO MARRONE O IN LEGNO LACCATO LUCIDO NELLE FINITURE BIANCO, NERO, LILLA, GRIGIO VERDE, MOKA, SALMONE, TORTORA, VERDE

CATEGORIES TABLES - COFFEE TABLES/SIDE TABLES/CONSOLES - BOOKSHELVES/CABINETS/ACCESSORIES **PRODUCT** COFFEE TABLE - SIDE TABLE - CONSOLE **STRUCTURE** IN METAL WITH SATIN, CHROME, BLACK CHROME, BURNISHED OR CHAMPAGNE FINISH. RESTS ON PADS MADE OF THERMOPLASTIC MATERIAL **TOP ART. 14X60-14X61-14X62-14X69-14X64-14X65-14X68** IN SOLID CANALETTO WALNUT WITH NATURAL FINISH, OR STAINED CANALETTO WALNUT EXTRA OR COFFEE; OR, IN SOLID ASH WITH NATURAL FINISH OR STAINED WALNUT, CHERRY, TEAK, COFFEE, WENGE, EBONY OR BROWN; OR IN WOOD WITH GLOSSY LACQUER FINISH IN WHITE, BLACK, LILAC, GREY-GREEN, MOCHA, SALMON, DOVE GREY OR PINE GREEN; OR, IN THE FOLLOWING TYPES OF MARBLE: CALACATTA GOLD POLISHED OR MATTE, POLISHED WHITE CARRARA, POLISHED BLACK MARQUINA, EMPERADOR POLISHED OR MATTE **TOP ART. 14X50-14X51-14X66** IN SOLID CANALETTO WALNUT WITH NATURAL FINISH, OR STAINED CANALETTO WALNUT EXTRA OR COFFEE; OR, IN SOLID ASH WITH NATURAL FINISH OR STAINED WALNUT, CHERRY, TEAK, COFFEE, WENGE, EBONY OR BROWN; OR IN WOOD WITH GLOSSY LACQUER FINISH IN WHITE, BLACK, LILAC, GREY-GREEN, MOCHA, SALMON, DOVE GREY OR PINE GREEN

14X60

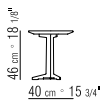

14X61



14X62

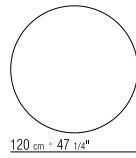
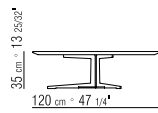

14X69

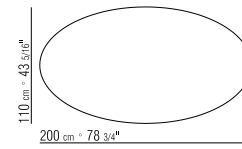
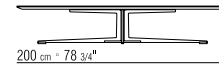
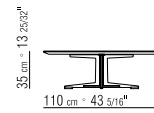

14X50

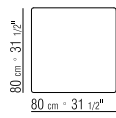
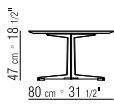

14X51

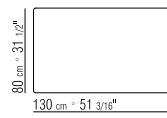
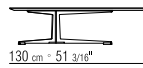
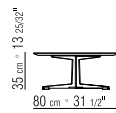

14X66

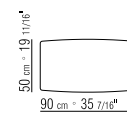
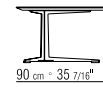

14X64

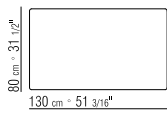
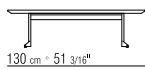
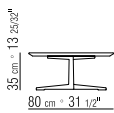

14X65

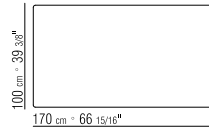
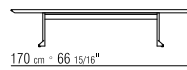
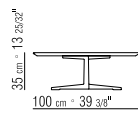

14X68

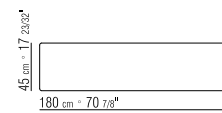
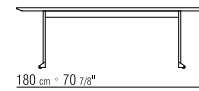

**COFFEE TABLES
SIDE TABLES
CONSOLES**

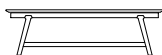

Una famiglia che comprende tavolini, consolle e pouf contraddistinti dalla scelta di materiali di grande pregio.

La pulizia formale del disegno si traduce in lavorazioni sapienti riconducibili alla tradizione ebanista.

La base dei tavolini interamente realizzata in massello di noce canaletto o frassino proposti in un'ampia gamma cromatica presenta un'elegante linea svasata che rende i tavolini e la consolle particolarmente leggeri alla vista.

Il piano può essere realizzato anch'esso in essenza per una scelta monomaterica di grande impatto oppure puntare al gioco dei contrasti attraverso la scelta del marmo.

Se il tavolino Giano trova la sua naturale collocazione di fronte ad un divano, la consolle può essere utilizzata sia alle spalle del divano quale funzionale piano d'appoggio sia come elemento a sé stante in un ingresso o a completamento dello spazio living.

The exquisite materials employed set this family of coffee tables, side tables, consoles and ottomans in a class of its own.

The aesthetic integrity of the design is enhanced by craftsmanship skills steeped in the cabinetmaking tradition.

The elegantly-flared lines of the table base – made of solid Canaletto walnut or ash, available in an array of stains – lend the tables and console an exceptional air of visual lightness.

The top can also be crafted in wood, for dramatic textural effect or, if marble is the material of choice, to create an interplay of contrasts.

If the Giano coffee table finds its natural habitat in front of a sofa, the console can be used behind the sofa, as a convenient table-top surface, as a stand-alone piece in an entry, or to complete the living room decor.



186



TIPOLOGIE POLTRONE/POUF - TAVOLINI/CONSOLLE **PRODOTTO** TAVOLINO - CONSOLLE **STRUTTURA** IN LEGNO MASSELLO DI NOCE CANALETTO NELLE FINITURE NATURALE, TINTO EXTRA, TINTO CAFFÈ; O MASSELLO DI FRASSINO NELLE FINITURE NATURALE, TINTO NOCE, TINTO CILIEGIO, TINTO TEAK, TINTO CAFFÈ, TINTO WENGÉ, TINTO EBANO, TINTO MARRONE. APOGGIO A TERRA SU PUNTALI IN MATERIALE TERMOPLASTICO **PIANO** IN LEGNO MASSELLO DI NOCE CANALETTO NELLE FINITURE NATURALE, TINTO EXTRA, TINTO CAFFÈ; O MASSELLO DI FRASSINO NELLE FINITURE NATURALE, TINTO NOCE, TINTO CILIEGIO, TINTO TEAK, TINTO COLORE CAFFÈ, TINTO WENGÉ, TINTO EBANO, TINTO MARRONE; O IN MARMO NELLE TIPOLOGIE CALACATTA ORO LUCIDO, MARMO CALACATTA ORO OPACO, BIANCO CARRARA LUCIDO, NERO MARQUINA LUCIDO, EMPERADOR LUCIDO, EMPERADOR OPACO

CATEGORIES ARMCHAIRS/OTTOMANS - COFFEE TABLES/SIDE TABLES/CONSOLES **PRODUCT** COFFEE TABLE - CONSOLE **STRUCTURE** IN SOLID CANALETTO WALNUT WITH NATURAL FINISH, OR STAINED CANALETTO WALNUT EXTRA OR COFFEE; OR, IN SOLID ASH WITH NATURAL FINISH OR STAINED WALNUT, CHERRY, TEAK, COFFEE, WENGE, EBONY OR BROWN. RESTS ON PADS MADE OF THERMOPLASTIC MATERIAL **TOP** IN SOLID CANALETTO WALNUT WITH NATURAL FINISH, OR STAINED CANALETTO WALNUT EXTRA OR COFFEE; OR, IN ASH WITH NATURAL FINISH OR STAINED WALNUT, CHERRY, TEAK, COFFEE, WENGE, EBONY OR BROWN; OR, IN THE FOLLOWING TYPES OF MARBLE: CALACATTA GOLD POLISHED OR MATTE, POLISHED WHITE CARRARA, POLISHED BLACK MARQUINA, EMPERADOR POLISHED OR MATTE

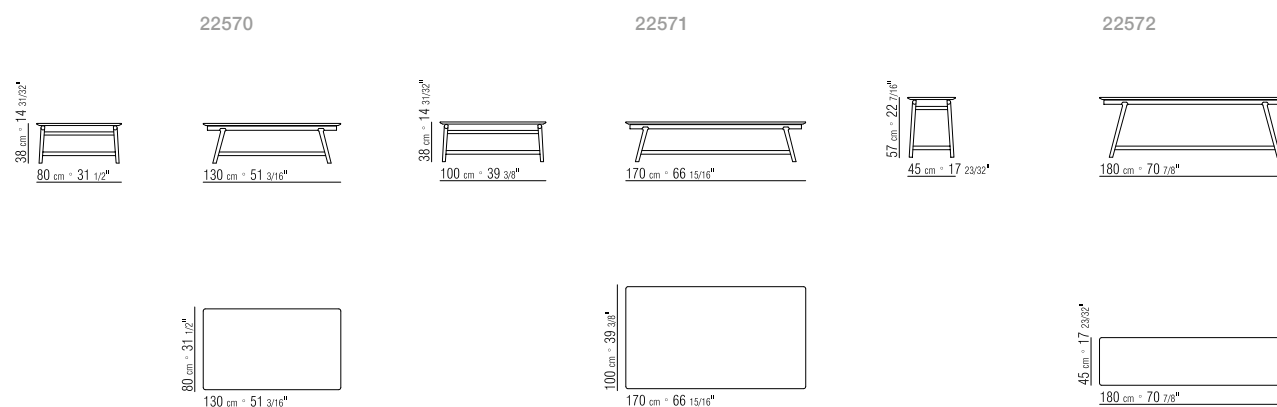

Giano

Data Sheet

Gipsy

Antonio Citterio 2013

188

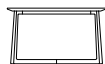

COFFEE TABLES SIDE TABLES CONSOLES

La collezione di tavoli, tavolini e consolle Gipsy è caratterizzata da linee pulite e durature.

I tavolini Gipsy presentano una raffinata base in massello di noce canaletto e frassino in una varietà di tinte.

La ricercata lavorazione della gamba a sezione quadrata che si congiunge nella base di appoggio a terra con un bel gioco di geometrie esalta la poetica matericità del legno e crea un interessante contrasto con il piano proposto nelle versioni laccato lucido in una sofisticata palette di colori oppure in pregiato marmo.

I tavolini Gipsy sono disponibili in diverse misure, che consentono di creare un impatto visivo alquanto interessante quando utilizzati insieme.

The Gipsy collection of tables, coffee tables and consoles features clean, timeless lines.

The elegant base of the Gipsy tables is made of solid Canaletto walnut or ash, stained in a number of shades.

The sophisticated workmanship of the square legs that join the support base in a lively interplay of geometries, exalts the poetic texture and feel of the wood, creating an intriguing contrast with the top, which comes in versions with glossy lacquer finish, in a sophisticated palette of colors, or in luxurious marble.

The Gipsy tables are available in several sizes and, when placed together, create stunning visual impact.



TIPOLOGIE TAVOLI - TAVOLINI/CONSOLLE **PRODOTTO** TAVOLINO - CONSOLLE
STRUTTURA IN LEGNO MASSELLO DI NOCE CANALETTO NELLE FINITURE NATURALE, TINTO EXTRA, TINTO CAFFÈ O MASSELLO DI FRASSINO NELLE FINITURE NATURALE, TINTO NOCE, TINTO CILIEGIO, TINTO TEAK, TINTO COLORE CAFFÈ, TINTO WENGÉ, TINTO EBANO, TINTO MARRONE. APPOGGIO A TERRA SU PUNTALI IN MATERIALE TERMOPLASTICO **PIANO** IN LEGNO LACCATO LUCIDO NELLE FINITURE BIANCO, NERO, LILLA, GRIGIO VERDE, MOKA, SALMONE, TORTORA, VERDE PINO; O IN MARMO NELLE TIPOLOGIE CALACATTA ORO LUCIDO, MARMO CALACATTA ORO OPACO, BIANCO CARRARA LUCIDO, NERO MARQUINIA LUCIDO, EMPERADOR LUCIDO, EMPERADOR OPACO

CATEGORIES TABLES - COFFEE TABLES/SIDE TABLES/CONSOLES **PRODUCT** COFFEE TABLE - SIDE TABLE - CONSOLE **STRUCTURE** IN SOLID CANALETTO WALNUT WITH NATURAL FINISH, OR STAINED CANALETTO WALNUT EXTRA OR COFFEE; OR, IN SOLID ASH WITH NATURAL FINISH OR STAINED WALNUT, CHERRY, TEAK, COFFEE, WENGE, EBONY OR BROWN. RESTS ON PADS MADE OF THERMOPLASTIC MATERIAL **TOP** IN WOOD WITH GLOSSY LACQUER FINISH IN WHITE, BLACK, LILAC, GREY-GREEN, MOCHA, SALMON PINK, DOVE GREY, PINE GREEN; OR IN THE FOLLOWING TYPES OF MARBLE: CALACATTA GOLD POLISHED OR MATTE, POLISHED WHITE CARRARA, POLISHED BLACK MARQUINA, EMPERADOR POLISHED OR MATTE



20170

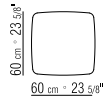
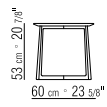

20172

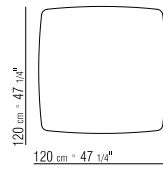
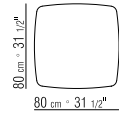
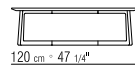
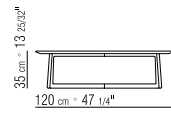
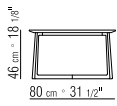

Groundpiece

Antonio Citterio 2001

192



COFFEE TABLES SIDE TABLES CONSOLES

Progettati quali ideali complementi dell'omonimo divano best-seller, i tavolini Groundpiece presentano una linea pura ed essenziale che trova la sua consacrazione nella scelta del materiale di rivestimento: l'affascinante eterno cuoio.

Proposti in due misure, i tavolini Groundpiece hanno una solida struttura in metallo interamente rivestita in cuoio e sono dotati di pratici quanto capienti vani portaoggetti.

Si mantengono sollevati da terra attraverso la medesima base in metallo utilizzata per il divano Groundpiece.

Designed as the perfect complement to the best-selling namesake sofa, the pure, uncluttered lines of the Groundpiece coffee and side tables are exalted by their upholstery: fascinating, timeless cowhide.

Available in two sizes, the Groundpiece tables have a solid metal structure clad entirely in cowhide and are designed with useful, roomy storage compartments.

They rise off the floor on the same metal base found on the Groundpiece sofa.







The Groundpiece coffee table features a geometrical metal structure entirely clad in saddle hide and is fitted with useful storage compartments.

196



TIPOLOGIE DIVANI/DIVANI componibili/ POUF - TAVOLINI/CONSOLLE - LIBRERIE/COMPLEMENTI/CONTENITORI - LETTI **PRODOTTO** TAVOLINO **STRUTTURA** IN METALLO RIVESTITA IN CUIOIO NEI COLORI BIANCO 5007, GRIGIO 5003, TESTA DI MORO 5004, TESTA DI MORO SCURO 5013, NERO 5005, OLIVA 5006, ROSSO BULGARO 5008, SABBIA 5001, TABACCO 5015, SCAMOSCIATO MORO 6004, SCAMOSCIATO NERO 6005, SCAMOSCIATO OLIVA 6003, SCAMOSCIATO SABBIA 6001 **PIEDI** IN METALLO VERNICIATO A FORNO CON POLVERI EPOSSIDICHE. APPOGGIO A TERRA SU PUNTALI IN MATERIALE TERMOPLASTICO

CATEGORIES SOFAS/SECTIONAL SOFAS/OTTOMANS - COFFEE TABLES/SIDE TABLES/CONSOLES - BOOKSHELVES/FURNISHINGS/CABINETS - BEDS **PRODUCT** COFFEE TABLE **STRUCTURE** IN METAL UPHOLSTERED IN COWHIDE IN THE FOLLOWING COLORS: WHITE 5007, GREY 5003, DARK BROWN 5004, EXTRA DARK BROWN 5013, BLACK 5005, OLIVE 5006, BULGARIAN RED 5008, SAND 5001 OR TOBACCO 5015; OR, IN SUEDE: DARK BROWN 6004, BLACK 6005, OLIVE 6003 OR SAND 6001 **FEET** IN EPOXY POWDER-COATED METAL. RESTS ON PADS MADE OF THERMOPLASTIC MATERIAL

11M87

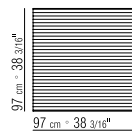
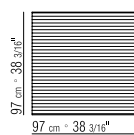
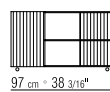
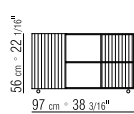
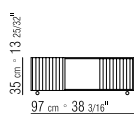

Groundpiece Data Sheet

Gustav

Carlo Colombo 2018

198



**COFFEE TABLES
SIDE TABLES
CONSOLES**

Una famiglia di tavoli e tavolini caratterizzati dalla purezza del disegno e da una grande praticità d'utilizzo.

Ricercati dettagli come l'innesto della gamba con il piano del tavolo celano la complessità costruttiva in una semplicità soltanto apparente. Raffinate le combinazioni materiche tra la struttura in massello di noce canaletto e frassino ed il piano inserito a filo, che può essere realizzato in diverse varietà di marmo: Bianco Carrara, Nero Marquina, Calacatta Oro ed Emperador.

Pensati quali ideali elementi di servizio alle sedute della collezione, i tavolini Gustav mostrano una loro spiccata personalità ed un'attitudine a presentarsi da soli o in gruppo, per meglio valorizzare il gioco delle sovrapposizioni.

Purity of design and functionality are in the design DNA of this family of dining and accent tables.

Sophisticated details, like the leg that inserts into the table top, conceal the complexities of construction under the guise of simplicity. Exquisite combinations of materials are possible between the structure in solid Canaletto walnut and ash and the flush-set top in several kinds of marble: White Carrara, Black Marquina, Calacatta Gold and Emperador. Designed as the perfect complements to the seating options in the collection, the Gustav side tables have bold personality and a flair for standing alone or in groups, where the interplay of overlapping planes is even more evident.



200



TIPOLOGIE TAVOLINI/CONSOLLE **PRODOTTO** TAVOLINO **STRUTTURA** IN LEGNO MASSELLO DI NOCE CANALETTO NELLE FINITURE NATURALE, TINTO EXTRA, TINTO CAFFÈ; O MASSELLO DI FRASSINO NELLE FINITURE NATURALE, TINTO NOCE, TINTO CILIEGIO, TINTO TEAK, TINTO CAFFÈ, TINTO WENGÉ, TINTO EBANO, TINTO MARRONE. APPOGGIO A TERRA SU PUNTALI IN MATERIALE TERMOPLASTICO **PIANO** IN MARMO NELLE TIPOLOGIE CALACATTA ORO LUCIDO, MARMO CALACATTA ORO OPACO, BIANCO CARRARA LUCIDO, NERO MARQUINIA LUCIDO, EMPERADOR LUCIDO, EMPERADOR OPACO

CATEGORIES COFFEE TABLES/SIDE TABLES/CONSOLES **PRODUCT** COFFEE TABLE - SIDE TABLE **STRUCTURE** IN SOLID CANALETTO WALNUT WITH NATURAL FINISH, OR STAINED CANALETTO WALNUT EXTRA OR COFFEE; OR, IN SOLID ASH WITH NATURAL FINISH OR STAINED WALNUT, CHERRY, TEAK, COFFEE, WENGE, EBONY OR BROWN. RESTS ON PADS MADE OF THERMOPLASTIC MATERIAL **TOP** IN THE FOLLOWING TYPES OF MARBLE: CALACATTA GOLD POLISHED OR MATTE, POLISHED WHITE CARRARA, POLISHED BLACK MARQUINA, EMPERADOR POLISHED OR MATTE

24970/24975

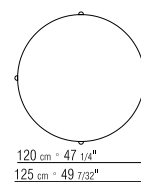
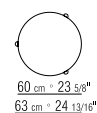
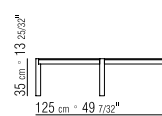
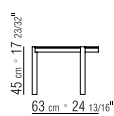
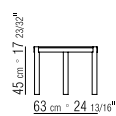
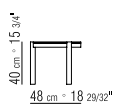
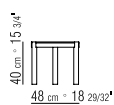

Infinity

Antonio Citterio 2004

202

**COFFEE TABLES
SIDE TABLES
CONSOLES**

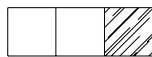

Il tavolino Infinity è improntato al medesimo concept progettuale dell'omonima libreria.

Infinity è un sistema costituito da moduli in metallo smaltato con polveri epossidiche in un'ampia gamma cromatica, liberamente aggregabili tra loro tramite un'invisibile vite di congiunzione in acciaio satinato.

I moduli del sistema Infinity consentono di realizzare diverse configurazioni del tavolino, che può essere collocato sia accanto ai divani che davanti.

I moduli in lamiera metallica possono essere completati con le scatole Box in cuoio, da utilizzarsi quali pratici contenitori.

The Infinity coffee table is informed by the same aesthetic concept as its namesake bookcase.

A system made of epoxy-powder-coated metal containers that come in an extensive array of colors, Infinity modules can be freely combined and joined to each other by an invisible satin-finish steel connector screw.

Various configurations of the coffee table can be created using the Infinity system modules, making it right at home in front of or alongside a sofa.

Used as handy containers, the cowhide Box baskets are an ideal textural complement to the sheet metal modules.



TIPOLOGIE TAVOLINI/CONSOLLE - LIBRERIE/COMPLEMENTI/CONTENITORI **PRODOTTO** TAVOLINO **STRUTTURA** IN METALLO INTERNAMENTE ED ESTERNAMENTE VERNICIATA A FORNO CON POLVERI EPOSSIDICHE NEI COLORI BIANCO 100, BEIGE PERLATO 130, BIANCO CREMA 150, BIANCO OPACO 160, PANNA 205, ROSSO VINO 405, VERDE KAKI 705, GRIGIO OMBRA 720, GRIGIO TOPO PERLATO 740, MARRONE GRIGIO 805, NERO 900 **TOP** IN METALLO VERNICIATO A FORNO CON POLVERI EPOSSIDICHE E CRISTALLO RETROVERNICIATO NEI COLORI BIANCO 100, BEIGE PERLATO 130, BIANCO CREMA 150, BIANCO OPACO 160, PANNA 205, ROSSO VINO 405, VERDE KAKI 705, GRIGIO OMBRA 720, GRIGIO TOPO PERLATO 740, MARRONE GRIGIO 805, NERO 900 **CONGIUNZIONI** IN ACCIAIO SATINATO **BASAMENTO** IN METALLO CROMATO

CATEGORIES COFFEE TABLES/SIDE TABLES/CONSOLES - BOOKSHELVES/FURNISHINGS/CABINETS **PRODUCT** COFFEE TABLE - SIDE TABLE **STRUCTURE** IN EPOXY-POWDER-COATED METAL, ENAMELED INSIDE AND OUT IN THE FOLLOWING COLORS: WHITE 100, PEARL BEIGE 130, CREAM-WHITE 150, MATTE WHITE 160, CREAM 205, WINE RED 405, KHAKI GREEN 705, UMBRA GREY 720, PEARL MOUSE GREY 740, GREY BROWN 805, BLACK 900 **TOP** IN EPOXY-POWDER-COATED METAL AND BACKPAINTED GLASS, ENAMELED IN THE FOLLOWING COLORS: WHITE 100, PEARL BEIGE 130, CREAM-WHITE 150, MATTE WHITE 160, CREAM 205, WINE RED 405, KHAKI GREEN 705, UMBRA GREY 720, PEARL MOUSE GREY 740, GREY BROWN 805, BLACK 900 **CONNECTORS** IN SATIN-FINISH STEEL **BASE** IN METAL WITH CHROME FINISH



12D40
BASE

12D42
BASE

12D44
BASE

12D45
BASE

12D46
BASE

1.5 cm = 0.1932"

40 cm = 15 3/4"

40 cm = 15 3/4"

80 cm = 31 1/2"

120 cm = 47 1/4"

160 cm = 62 15/16"

200 cm = 78 3/4"

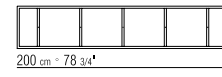
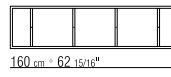
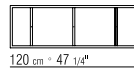
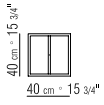

12D50
BASE

12D51
BASE

12D52
BASE

12D53
BASE

12D54
BASE

1.5 cm = 0.1932"

80 cm = 31 1/2"

80 cm = 31 1/2"

120 cm = 47 1/4"

160 cm = 63"

200 cm = 78 3/4"

1.5 cm = 0.1932"

120 cm = 47 1/4"

120 cm = 47 1/4"

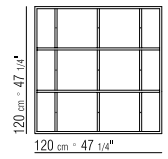
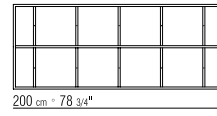
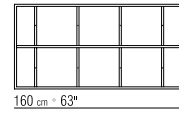
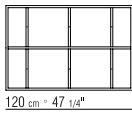
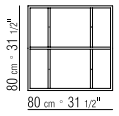

12D26
MODULO / UNIT

12D20
MODULO / UNIT

12D21
MODULO / UNIT

0.3 cm = 0.118"

40 cm = 15 3/4"

40 cm = 15 3/4"

20 cm = 7.76"

40 cm = 15 3/4"

40 cm = 15 3/4"

20 cm = 7.76"

80 cm = 31 1/2"

40 cm = 15 3/4"

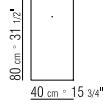
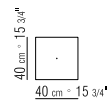
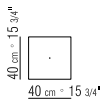

12D22
MODULO / UNIT

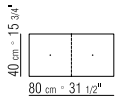
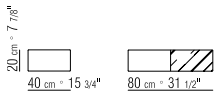

12D23
MODULO / UNIT

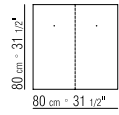
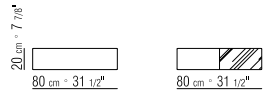

12D24
MODULO / UNIT

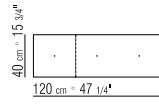
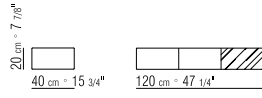

12D30
MODULO / UNIT

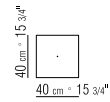
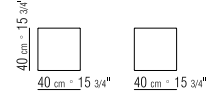

12D31
MODULO / UNIT

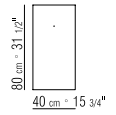
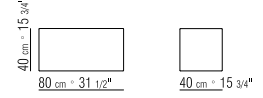

12D32
MODULO / UNIT

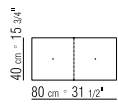
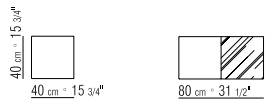

12D33
MODULO / UNIT

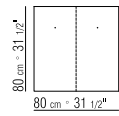
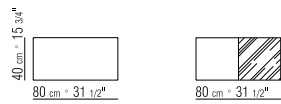

12D34
MODULO / UNIT

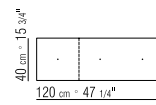
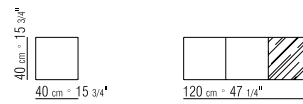

12D74
TOP

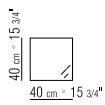
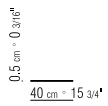

12D55
TOP



12D56
TOP

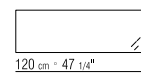
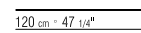

12D58
TOP

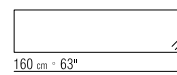
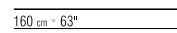

12D60
TOP

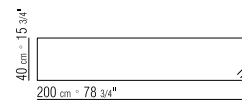
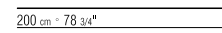

12D64
TOP

12D66
TOP

12D68
TOP

12D70
TOP

12D76
TOP

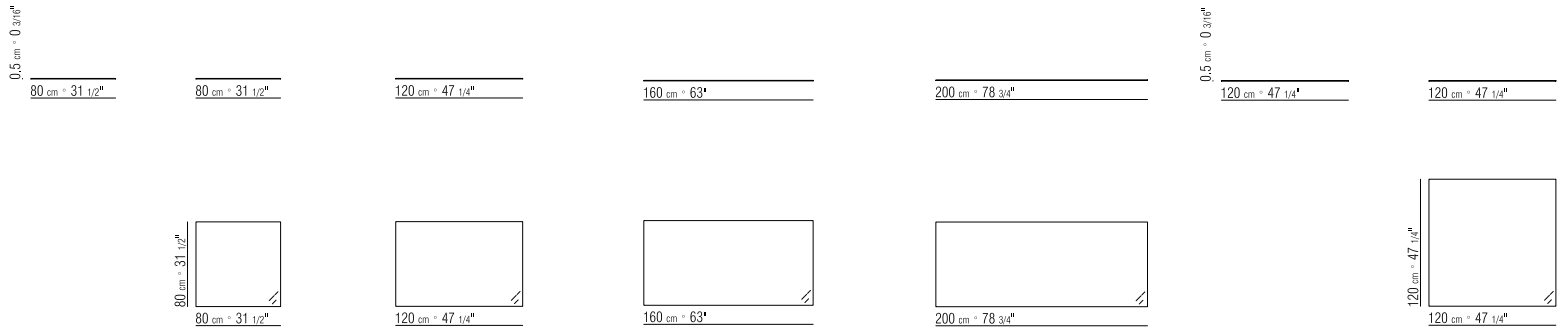

COMPOSIZIONI / COMPOSITIONS

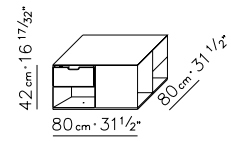
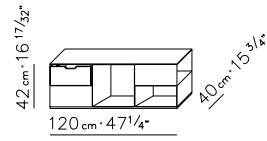
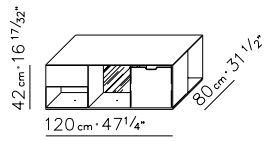
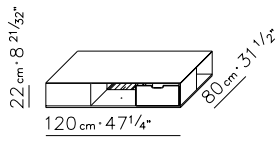
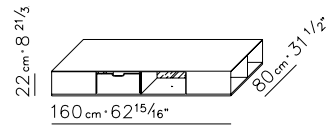
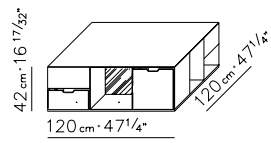
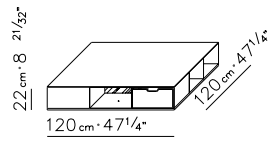

**COFFEE TABLES
SIDE TABLES
CONSOLES**



Alla purezza del disegno e alla ricercatezza dei dettagli costruttivi che caratterizzano i tavolini e la consolle Jiff, si accompagna la scelta di un concept monomaterico, che si esprime nella scelta di un materiale caldo ed espressivo come il legno.

Solo ed unicamente legno massello - noce canaletto e frassino proposti in una varietà di tinte raffinate - sia per la struttura che per il piano dai bordi smussati.

Originale e ad effetto il disegno delle tre gambe che confluiscono unendosi alla base in un unico elemento a sorreggere il piano.

I tavolini Jiff possono essere armoniosamente abbinati a tutte le sedute della collezione Flexform, da soli o accostati tra loro in un elegante gioco di sovrapposizioni.

The Jiff coffee tables, side tables and console express a purity of design and refined construction that marries well with the 'monomaterial' concept conveyed through a warm, vibrant material like wood.

Both the structure and the beveled-edge top are solely and exclusively made of solid wood – Canaletto walnut or ash, available in a number of sophisticated stain finishes.

The design effect of the three legs that flow together, joining at the base in a single element to support the top, is unique and striking.

The Jiff tables can confidently be paired with any of the seating elements in the Flexform collection, by themselves or combined for a subtle interplay of overlapping planes.



TIPOLOGIE TAVOLI - TAVOLINI/CONSOLLE **PRODOTTO** TAVOLINO - CONSOLLE
STRUTTURA E PIANO IN LEGNO MASSELLO DI NOCE CANALETTO NELLE FINITURE
NATURALE, TINTO EXTRA, TINTO CAFFÈ; O MASSELLO DI FRASSINO NELLE FINITURE
NATURALE, TINTO NOCE, TINTO CILIEGIO, TINTO TEAK, TINTO CAFFÈ, TINTO WENGÉ,
TINTO EBANO, TINTO MARRONE. PER GLI ART. 11Z70-11Z71-11Z72 DISPONIBILE
ANCHE IN LEGNO LACCATO LUCIDO NEI COLORI BIANCO, NERO, LILLA, GRIGIO
VERDE, MOKA, SALMONE, TORTORA, VERDE PINO. APPOGGIO A TERRA SU PUNTALI
IN MATERIALE TERMOPLASTICO

CATEGORIES TABLES - COFFEE TABLES/SIDE TABLES/CONSOLES **PRODUCT**
COFFEE TABLE - SIDE TABLE - CONSOLE **STRUCTURE AND TOP** IN SOLID
CANALETTO WALNUT WITH NATURAL FINISH OR STAINED CANALETTO WALNUT
EXTRA OR COFFEE; OR, IN SOLID ASH WITH NATURAL FINISH OR STAINED WALNUT,
CHERRY, TEAK, COFFEE, WENGE, EBONY OR BROWN. ART. 11Z70-11Z71-11Z72 ALSO
AVAILABLE IN WOOD WITH GLOSSY LACQUER FINISH IN WHITE, BLACK, LILAC,
GREY-GREEN, MOCHA, SALMON PINK, DOVE GREY OR PINE GREEN. RESTS ON
PADS MADE OF THERMOPLASTIC MATERIAL



11Z70

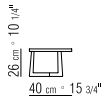

11Z71

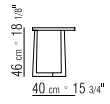

11Z72

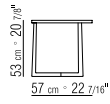

11Z76

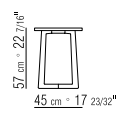
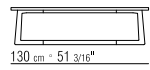
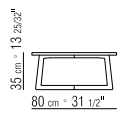

11Z60

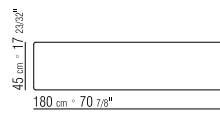
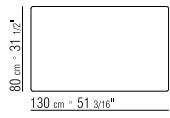
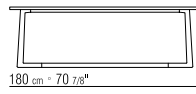

Kidd

Antonio Citterio 2003

212



**COFFEE TABLES
SIDE TABLES
CONSOLES**

La famiglia di tavolini Kidd è caratterizzata da un'originale base in metallo, proposta nelle finiture satinato, cromato, brunito, cromo nero e champagne.

Il piano di forma tonda inserito a filo nella struttura in metallo può essere realizzato in una pluralità di finiture: legno laccato con particolari vernici antigraffio nei colori bianco e nero, legno laccato lucido in una sofisticata palette cromatica e anche in noce canaletto o frassino, tinti in numerose nuance.

I tavolini Kidd sono disponibili in tre misure e possono essere armoniosamente abbinati a tutte le sedute della collezione Flexform, da soli o accostati tra loro in un elegante gioco di sovrapposizioni.

The Kidd family of coffee and side tables features an original metal base, in satin, chrome, burnished, black chrome or champagne finish.

The round top, set flush in the metal structure, can be crafted in a number of different finishes – wood lacquered in black or white with special scratch-proof paints; glossy-lacquered wood in a sophisticated color palette; or in Canaletto walnut or ash, stained in various shades.

The Kidd coffee tables come in three sizes and can confidently be paired with any of the seating elements in the Flexform collection, by themselves or grouped in a sophisticated arrangement of overlapping pieces.



214



TIPOLOGIE TAVOLINI/CONSOLLE **PRODOTTO** TAVOLINO **STRUTTURA** IN METALLO NELLE FINITURE SATINATO, CROMATO, CROMO NERO, BRUNITO, CHAMPAGNE **PIANI** IN LEGNO TRATTATO CON VERNICE ANTIGRAFFIO E AD ALTA RESISTENZA NEI COLORI BIANCO 102, NERO 902; O IN LEGNO IMPIALLACCIATO DI NOCE CANALETTO NELLE FINITURE NATURALE, TINTO EXTRA, TINTO CAFFÈ O IMPIALLACCIATO DI FRASSINO NELLE FINITURE NATURALE, TINTO NOCE, TINTO CILIEGIO, TINTO TEAK, TINTO CAFFÈ, TINTO WENGÉ, TINTO EBANO, TINTO MARRONE; O IN LEGNO LACCATO LUCIDO NEI COLORI BIANCO, NERO, LILLA, GRIGIO VERDE, MOKA, SALMONE, TORTORA, VERDE PINO

CATEGORIES COFFEE TABLES/SIDE TABLES/CONSOLES **PRODUCT** SIDE TABLE **STRUCTURE** IN METAL WITH SATIN, CHROME, BLACK CHROME, BURNISHED OR CHAMPAGNE FINISH **TOPS** IN WOOD FINISHED WITH HIGHLY SCRATCH-RESISTANT PAINT IN WHITE 102 OR BLACK 902; IN CANALETTO WALNUT VENEER IN THE FOLLOWING FINISHES: NATURAL, OR STAINED CANALETTO WALNUT EXTRA OR COFFEE; OR, IN ASH VENEER WITH NATURAL FINISH OR STAINED WALNUT, CHERRY, TEAK, COFFEE, WENGE, EBONY OR BROWN; OR, IN WOOD WITH GLOSSY LACQUER FINISH IN WHITE, BLACK, LILAC, GREY-GREEN, MOCHA, SALMON, DOVE GREY OR PINE GREEN

11Y70

11Y71

11Y72

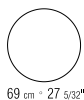
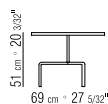
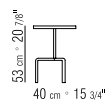
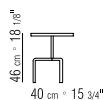

Kidd

Data Sheet

Oliver

Design Center 2006

216

Agile e minuto ma non per questo privo di carattere, il tavolino Oliver è interamente realizzato in legno massello – noce canaletto e frassino tinti in numerose nuance - e rivela quell'attitudine tipica dell'azienda a fare propria la tradizione ebanista.

Il tavolino Oliver è particolarmente leggero e maneggevole e può essere facilmente spostato all'occorrenza per essere collocato in prossimità di una seduta e ricoprire la funzione di pratico piano d'appoggio per posare un bicchiere, un libro, un oggetto.

Oliver è un pezzo facile e ben risolto apprezzato da tutti coloro che amano la funzionalità associata all'eleganza.

The company's aptitude for embracing the cabinetmaking tradition as its own is exemplified in the Oliver side table. Sleek and small, but by no means lacking in character, it is made entirely of solid wood and is available in Canaletto walnut or ash, stained in various shades.

Especially light, the Oliver side table can easily be moved, as needed, closer to a chair or sofa as a handy table top to accommodate a glass, book or object.

In its simplicity, Oliver is a well-thought-out piece, popular with all those who value function wed to elegance.



**COFFEE TABLES
SIDE TABLES
CONSOLES**



218



TIPOLOGIE TAVOLINI/CONSOLLE **PRODOTTO** TAVOLINO **STRUTTURA E PIANO** IN LEGNO MASSELLO DI NOCE CANALETTO NELLE FINITURE NATURALE, TINTO EXTRA, TINTO CAFFÈ O MASSELLO DI FRASSINO NELLE FINITURE NATURALE, TINTO NOCE, TINTO CILIEGIO, TINTO TEAK, TINTO CAFFÈ, TINTO WENGÉ, TINTO EBANO, TINTO MARRONE

CATEGORIES COFFEE TABLES/SIDE TABLES/CONSOLES **PRODUCT** SIDE TABLE **STRUCTURE AND TOP** IN SOLID CANALETTO WALNUT WITH NATURAL FINISH OR STAINED CANALETTO WALNUT EXTRA OR COFFEE; OR, IN SOLID ASH WITH NATURAL FINISH OR STAINED WALNUT, CHERRY, TEAK, COFFEE, WENGE, EBONY OR BROWN

12Y71

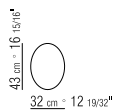
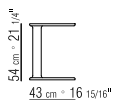

Oliver
Data Sheet

Plain

Antonio Citterio 2003

220

**COFFEE TABLES
SIDE TABLES
CONSOLES**



Rigoroso ed essenziale nella sua forma geometrica che disegna una C, Plain è un funzionale tavolino d'appoggio pensato per una collocazione laterale o frontale al divano.

Forma e funzione trovano un'efficace sintesi, la semplicità delle linee incontra un materiale pregiato come il cuoio.

La struttura del tavolino Plain è in metallo ed è interamente rivestita in cuoio, nella vasta gamma cromatica proposta da Flexform.

With its sleek, uncluttered geometric C-shape, Plain is a handy tray table designed to be placed alongside or in front of the sofa.

Form and function combine seamlessly and its uncluttered lines provide the perfect foil for a luxurious material like cowhide.

The metal structure of the Plain side table is entirely clad in cowhide, available in the vast Flexform color palette.



222



TIPOLOGIE TAVOLINI/CONSOLLE **PRODOTTO** TAVOLINO **STRUTTURA** IN METALLO RIVESTITA IN CUIO IN COLORI BIANCO 5007, GRIGIO 5003, TESTA DI MORO 5004, TESTA DI MORO SCURO 5013, NERO 5005, OLIVA 5006, ROSSO BULGARO 5008, SABBIA 5001, TABACCO 5015, SCAMOSCIATO MORO 6004, SCAMOSCIATO NERO 6005, SCAMOSCIATO OLIVA 6003, SCAMOSCIATO SABBIA 6001

CATEGORIES COFFEE TABLES/SIDE TABLES/CONSOLES **PRODUCT** SIDE TABLE **STRUCTURE** IN METAL UPHOLSTERED IN COWHIDE IN THE FOLLOWING COLORS: WHITE 5007, GREY 5003, DARK BROWN 5004, EXTRA DARK BROWN 5013, BLACK 5005, OLIVE 5006, BULGARIAN RED 5008, SAND 5001 OR TOBACCO 5015; OR, IN SUEDE: DARK BROWN 6004, BLACK 6005, OLIVE 6003 OR SAND 6001

11W70

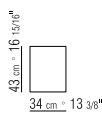
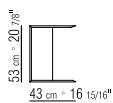

Plain
Data Sheet

Soffio

Antonio Citterio 2015

224

**COFFEE TABLES
SIDE TABLES
CONSOLES**



La collezione di tavoli, tavolini e consolle Soffio presenta una rigorosa costruzione architettonica.

Le gambe in metallo a sezione piatta rappresentano il segno distintivo del progetto. Salgono leggere e disegnano un'originale forma a "boomerang" che rende lo stacco da terra particolarmente dinamico.

Solidi ed aerei al contempo, i tavolini Soffio mostrano un interessante contrasto tra la leggerezza della base in metallo – disponibile nelle finiture satinato, cromato, brunito, cromo nero e champagne – e l'essenziale piano di forma rettangolare proposto nelle versioni legno canaletto o frassino in varie nuance oppure in pregiato marmo.

The Soffio collection of coffee tables, side tables and consoles displays an austere architectural attitude.

The flat metal legs are a hallmark feature of the design. Ascending lightly, they design an original "boomerang" shape that sends a dynamic current through the space between the table and the floor.

Solid yet airy, the Soffio coffee tables reflect the fascinating contrast between the lightness of the metal base – available in satin, chrome, burnished, black chrome or champagne finish – and the sleek rectangular top, available in Canaletto walnut or ash, stained in a number of colors, or in luxurious marble.



226





TIPOLOGIE TAVOLI - TAVOLINI/CONSOLLE **PRODOTTO** TAVOLINO - CONSOLLE
STRUTTURA IN METALLO NELLE FINITURE SATINATO, CROMATO, CROMO NERO, BRUNITO, CHAMPAGNE. APPOGGIO A TERRA SU PUNTALI IN MATERIALE TERMOPLASTICO **PIANO** IN LEGNO MASSELLO DI NOCE CANALETTO NELLE FINITURE NATURALE, TINTO EXTRA, TINTO CAFFÈ; O MASSELLO DI FRASSINO NELLE FINITURE NATURALE, TINTO NOCE, TINTO CILIEGIO, TINTO TEAK, TINTO CAFFÈ, TINTO WENGÉ, TINTO EBANO, TINTO MARRONE; O IN MARMO NELLE TIPOLOGIE CALACATTA ORO LUCIDO, MARMO CALACATTA ORO OPACO, BIANCO CARRARA LUCIDO, NERO MARQUINIA LUCIDO, EMPERADOR LUCIDO, EMPERADOR OPACO CON SUPPORTO IN LEGNO MULTISTRATO

CATEGORIES TABLES - COFFEE TABLES/SIDE TABLES/CONSOLES **PRODUCT** COFFEE TABLE - CONSOLE **STRUCTURE** IN METAL WITH SATIN, CHROME, BLACK CHROME, BURNISHED OR CHAMPAGNE FINISH. RESTS ON PADS MADE OF THERMOPLASTIC MATERIAL **TOP** IN SOLID CANALETTO WALNUT WITH NATURAL FINISH, OR STAINED CANALETTO WALNUT EXTRA OR COFFEE; OR, IN SOLID ASH WITH NATURAL FINISH OR STAINED WALNUT, CHERRY, TEAK, COFFEE, WENGE, EBONY OR BROWN; OR, IN THE FOLLOWING TYPES OF MARBLE: CALACATTA GOLD POLISHED OR MATTE, POLISHED WHITE CARRARA, POLISHED BLACK MARQUINA, EMPERADOR POLISHED OR MATTE WITH PLYWOOD SUPPORT



22470

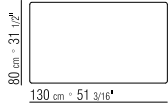
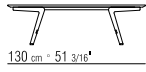
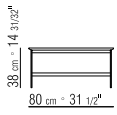

22471

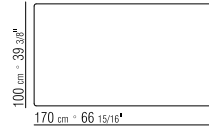
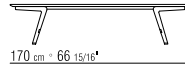
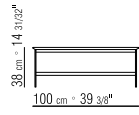

22472

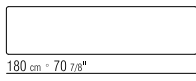
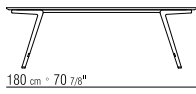
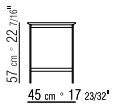

22473

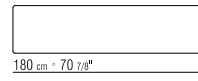
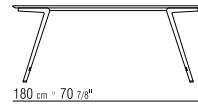
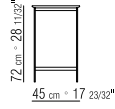

Sveva

Carlo Colombo 2018

230



**COFFEE TABLES
SIDE TABLES
CONSOLES**

Contraddistinti dalla medesima elegante base in metallo che caratterizza l'omonima poltrona, i tavolini Sveva presentano una loro spiccata personalità dovuta all'inconsueta forma dei piani.

Oltre che nella più usuale forma tonda, i piani dei tavolini Sveva sono proposti nell'originale forma esagonale ed in diverse misure, che consentono di realizzare un inconsueto quanto piacevole gioco di sovrapposizioni.

Prezioso l'abbinamento dei materiali: alle basi in metallo proposte nelle finiture satinato, cromato, brunito, cromo nero e champagne, possono essere associati piani in raffinate essenze, sofisticate laccature e pregiati marmi.

Distinguished by the same elegant metal base as the namesake armchair, the Sveva coffee/side tables express their bold personality through the unusual shape of their tops.

In addition to the more familiar round shape, the top of the Sveva coffee and side tables is available in a unique hexagonal shape in various sizes, allowing for the creation of a visually pleasing though unexpected interplay of overlapping shapes.

The pairing of luxurious materials only adds to their allure: the metal bases – available in satin, chrome, burnished, black chrome and champagne finish – can be matched with tops in sophisticated wood, lacquer or marble.



TIPOLOGIE POLTRONE/POUF - TAVOLINI/CONSOLLE **PRODOTTO** TAVOLINO
STRUTTURA IN METALLO SATINATO, CROMATO, BRUNITO O CROMO NERO, CHAMPAGNE **STRUTTURA** IN METALLO E ALLUMINIO PRESSOFUSO NELLE FINITURE SATINATO, CROMATO, CROMO NERO, BRUNITO, CHAMPAGNE. APPOGGIO A TERRA SU PUNTALI IN MATERIALE TERMOPLASTICO **PIANO** IN LEGNO MASSELLO DI NOCE CANALETTO NELLE FINITURE NATURALE, TINTO EXTRA, TINTO CAFFÈ; O MASSELLO DI FRASSINO NELLE FINITURE NATURALE, TINTO NOCE, TINTO CILIEGIO, TINTO TEAK, TINTO CAFFÈ, TINTO WENGÉ, TINTO EBANO, TINTO MARRONE; O IN LEGNO LACCATO LUCIDO NEI COLORI BIANCO, NERO, LILLA, GRIGIO VERDE, MOKA, SALMONE, TORTORA, VERDE PINO; O IN MARMO NELLE TIPOLOGIE CALACATTA ORO LUCIDO, MARMO CALACATTA ORO OPACO, BIANCO CARRARA LUCIDO, NERO MARQUINIA LUCIDO, EMPERADOR LUCIDO, EMPERADOR OPACO

CATEGORIES ARMCHAIRS/OTTOMANS - COFFEE TABLES/SIDE TABLES/CONSOLES
PRODUCT COFFEE AND SIDE TABLES **STRUCTURE** IN METAL AND CAST ALUMINUM WITH SATIN, CHROME, BLACK CHROME, BURNISHED OR CHAMPAGNE FINISH. RESTS ON PADS MADE OF THERMOPLASTIC MATERIAL **TOP** IN SOLID CANALETTO WALNUT WITH NATURAL FINISH, OR STAINED CANALETTO WALNUT EXTRA OR COFFEE; OR, IN SOLID ASH WITH NATURAL FINISH OR STAINED WALNUT, CHERRY, TEAK, COFFEE, WENGE, EBONY OR BROWN; OR IN WOOD WITH GLOSSY LACQUER FINISH IN WHITE, BLACK, LILAC, GREY-GREEN, MOCHA, SALMON, DOVE GREY OR PINE GREEN; OR, IN THE FOLLOWING TYPES OF MARBLE: CALACATTA GOLD POLISHED OR MATTE, POLISHED WHITE CARRARA, POLISHED BLACK MARQUINA, EMPERADOR POLISHED OR MATTE



24873

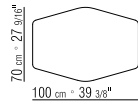
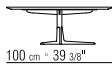

24876

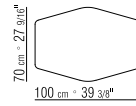
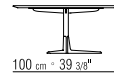

24878

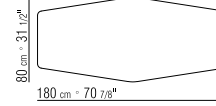
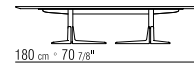
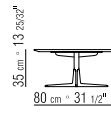

24875

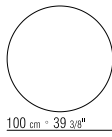
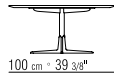
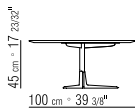

24872

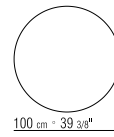
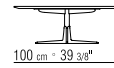
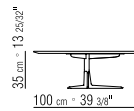

Tindari

Antonio Citterio 2015

234

**COFFEE TABLES
SIDE TABLES
CONSOLES**



Quando un accessorio diventa un piccolo capolavoro di artigianalità: il tavolino Tindari rappresenta perfettamente un tema assai caro a Flexform, quello dell'intreccio.

La struttura dei tavolini Tindari è in metallo tubolare nelle finiture satinato, cromato, brunito, cromo nero e champagne ed è interamente avviluppata in un prezioso intreccio in corda di cuoio. Metri e metri di cuoio intrecciati a mano da sapienti artigiani scaldano il rigore del metallo e danno vita ad un oggetto dal carattere unico.

Il piano può essere realizzato in massello di noce canaletto o frassino, tinti in raffinate nuance, oppure in pregiato marmo.

The art of weaving – when an accessory becomes a minor masterpiece of artisan craftsmanship. The Tindari side tables are exemplary of this theme that is enormously dear to Flexform.

The tubular metal structure of the Tindari side tables – available in satin, chrome, burnished, black chrome or champagne finish – is entirely enveloped in an exquisite cowhide cord weave. Meters and meters of cowhide, hand-woven by skilled artisans, warm the cool austerity of the metal and breathe life into a totally unique object.

The top can be crafted in solid Canaletto walnut or ash, stained in a number of sophisticated shades, or in luxurious marble.



236



TIPOLOGIE POLTRONE/POUF - TAVOLINI/CONSOLLE **PRODOTTO** TAVOLINO **STRUTTURA** IN METALLO NELLE FINITURE SATINATO, CROMATO, CROMO NERO, BRUNITO, CHAMPAGNE CON INTRECCIO IN CUIOIO NEI COLORI NERO, TESTA DI MORO, TABACCO, NATURALE, OLIVA, GRIGIO, ROSSO BULGARO **PIANO** IN LEGNO MASSELLO DI NOCE CANALETTO NELLE FINITURE NATURALE, TINTO EXTRA, TINTO CAFFÈ O MASSELLO DI FRASSINO NELLE FINITURE NATURALE, TINTO NOCE, TINTO CILIEGIO, TINTO TEAK, TINTO CAFFÈ, TINTO WENGÉ, TINTO EBANO, TINTO MARRONE O IN MARMO NELLE TIPOLOGIE CALACATTA ORO LUCIDO, MARMO CALACATTA ORO OPACO, BIANCO CARRARA LUCIDO, NERO MARQUINIA LUCIDO, EMPERADOR LUCIDO, EMPERADOR OPACO

CATEGORIES ARMCHAIRS/OTTOMANS - COFFEE TABLES/SIDE TABLES/CONSOLES **PRODUCT** COFFEE TABLE - SIDE TABLE **STRUCTURE** IN METAL WITH SATIN, CHROME, BLACK CHROME, BURNISHED OR CHAMPAGNE FINISH WITH WOVEN COWHIDE IN THE FOLLOWING COLORS: BLACK, DARK BROWN, TOBACCO, NATURAL, OLIVE, GREY, BULGARIAN RED **TOP** IN SOLID CANALETTO WALNUT WITH NATURAL FINISH, OR STAINED CANALETTO WALNUT EXTRA OR COFFEE; OR, IN SOLID ASH WITH NATURAL FINISH OR STAINED WALNUT, CHERRY, TEAK, COFFEE, WENGE, EBONY OR BROWN; OR, IN THE FOLLOWING TYPES OF MARBLE: CALACATTA GOLD POLISHED OR MATTE, POLISHED WHITE CARRARA, POLISHED BLACK MARQUINA, EMPERADOR POLISHED OR MATTE

22370

22371

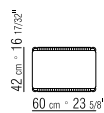
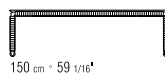
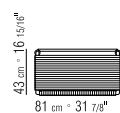
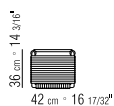

Tindari
Data Sheet

Tris

Design Center 2011

238

COFFEE TABLES SIDE TABLES CONSOLES



Una famiglia di tavolini che dichiara il gusto per il bello e per la semplicità delle forme.

La struttura è in legno massello – noce canaletto e frassino tinti in un'ampia gamma di nuance – e le quattro gambe caratterizzate da un'elegante sezione rastremata vanno a formare un disegno a crociera alla base del tavolino.

Il piano d'appoggio, di forma tonda e con bordo smussato, può essere realizzato anch'esso in legno, nelle medesime essenze della base oppure in pregiato marmo.

I tavolini Tris sono disponibili in quattro misure e possono essere armoniosamente abbinati a tutte le sedute della collezione Flexform, da soli o accostati tra loro in un raffinato gioco di sovrapposizioni.

This family of coffee tables asserts a taste for beauty and simplicity of form.

In Canaletto walnut or ash, stained in a wide array of shades, the solid wood structure and the four elegantly tapered legs form an X-shaped design at the base of the coffee table.

The table top, with beveled edge, can be crafted in the same wood as the base or in luxurious marble.

The Tris side tables come in three sizes and can confidently be paired with any of the seating elements in the Flexform collection, by themselves or grouped for a sophisticated interplay of overlapping planes.



240



TIPOLOGIE TAVOLINI/CONSOLLE **PRODOTTO** TAVOLINO **STRUTTURA** IN LEGNO MASSELLO DI NOCE CANALETTO NELLE FINITURE NATURALE, TINTO EXTRA, TINTO CAFFÈ; O MASSELLO DI FRASSINO NELLE FINITURE NATURALE, TINTO NOCE, TINTO CILIEGIO, TINTO TEAK, TINTO CAFFÈ, TINTO WENGÉ, TINTO EBANO, TINTO MARRONE. APPOGGIO A TERRA SU PUNTALI IN MATERIALE TERMOPLASTICO **PIANO** IN LEGNO MASSELLO DI NOCE CANALETTO NELLE FINITURE NATURALE, TINTO EXTRA, TINTO CAFFÈ; O MASSELLO DI FRASSINO NELLE FINITURE NATURALE, TINTO NOCE, TINTO CILIEGIO, TINTO TEAK, TINTO CAFFÈ, TINTO WENGÉ, TINTO EBANO, TINTO MARRONE; O IN MARMO NELLE TIPOLOGIE CALACATTA ORO LUCIDO, MARMO CALACATTA ORO OPACO, BIANCO CARRARA LUCIDO, NERO MARQUINIA LUCIDO, EMPERADOR LUCIDO, EMPERADOR OPACO

CATEGORIES COFFEE TABLES/SIDE TABLES/CONSOLES **PRODUCT** COFFEE TABLE - SIDE TABLE **STRUCTURE** IN SOLID CANALETTO WALNUT WITH NATURAL FINISH, OR STAINED CANALETTO WALNUT EXTRA OR COFFEE; OR, IN SOLID ASH WITH NATURAL FINISH OR STAINED WALNUT, CHERRY, TEAK, COFFEE, WENGE, EBONY OR BROWN. RESTS ON PADS MADE OF THERMOPLASTIC MATERIAL **TOP** IN SOLID CANALETTO WALNUT WITH NATURAL FINISH, OR STAINED CANALETTO WALNUT EXTRA OR COFFEE; OR, IN SOLID ASH WITH NATURAL FINISH OR STAINED WALNUT, CHERRY, TEAK, COFFEE, WENGE, EBONY OR BROWN; OR, IN THE FOLLOWING TYPES OF MARBLE: CALACATTA GOLD POLISHED OR MATTE, POLISHED WHITE CARRARA, POLISHED BLACK MARQUINA, EMPERADOR POLISHED OR MATTE

15P70



15P71

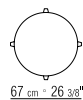
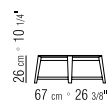

15P72

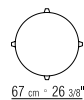
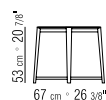

15P74

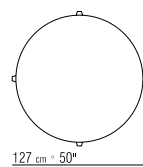
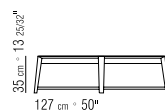

Tris

Data Sheet

Vienna

Design Center 2000

242



**COFFEE TABLES
SIDE TABLES
CONSOLES**

Echi dei motivi estetici tipici della Secessione Viennese, che ne ha ispirato il nome, nel tavolino Vienna contraddistinto da linee austere ma ricco nell'esecuzione.

Vienna è un raffinato tavolino d'appoggio, da collocare di lato o di fronte al divano, dalla raffinata sezione a C.

Interamente realizzato in legno massello – noce canaletto o frassino tinti in un'ampia gamma di finiture – il tavolino Vienna mostra un interessante gioco di montanti lignei paralleli che congiungono la base al piano.

Austere lines dense with expert craftsmanship echo the design motifs found in the Vienna Secession movement that inspired the Vienna side table's name.

A sophisticated tray table with an elegant C-shape design, Vienna can be placed alongside or in front of a sofa.

Made entirely of solid wood – Canaletto walnut or ash, stained in a wide array of shades – the Vienna tray table cleverly juxtaposes the parallel wood uprights that join the base to the top.



244



TIPOLOGIE TAVOLINI/CONSOLLE **PRODOTTO** TAVOLINO **STRUTTURA** IN LEGNO MASSELLO DI NOCE CANALETTO NELLE FINITURE NATURALE, TINTO EXTRA, TINTO CAFFÈ; O MASSELLO DI FRASSINO NELLE FINITURE NATURALE, TINTO NOCE, TINTO CILIEGIO, TINTO TEAK, TINTO CAFFÈ, TINTO WENGÉ, TINTO EBANO, TINTO MARRONE

CATEGORIES COFFEE TABLES/SIDE TABLES/CONSOLES **PRODUCT** SIDE TABLE **STRUCTURE** IN SOLID CANALETTO WALNUT WITH NATURAL FINISH, OR STAINED CANALETTO WALNUT EXTRA OR COFFEE; OR, IN SOLID ASH WITH NATURAL FINISH OR STAINED WALNUT, CHERRY, TEAK, COFFEE, WENGE, EBONY OR BROWN

11E70

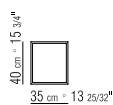
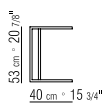

Vienna
Data Sheet

Zefiro

Antonio Citterio 2017

246

COFFEE TABLES SIDE TABLES CONSOLES



L'ampia collezione di tavolini Zefiro è caratterizzata da un segno lieve e contemporaneo.

I tavolini Zefiro sono estremamente versatili, grazie all'ampia gamma di misure e materiali con i quali possono essere realizzati e pertanto si inseriscono con stile ed eleganza in qualsiasi ambiente.

Le affusolate gambe in alluminio pressofuso disponibili nelle finiture satinato, cromato, brunito, cromo nero, champagne e verniciato nei colori bianco e nero conferiscono leggerezza e dinamicità al tavolino.

I piani sono proposti nelle varianti tondo, quadrato e rettangolare in una pluralità di misure e possono essere realizzati nelle versioni impiallacciato in noce canaletto o frassino in molteplici tinte, laccati lucidi in una gamma di raffinate nuance oppure in diverse varietà di pregiato marmo.

A light, contemporary edge defines the generous collection of Zefiro coffee and side tables.

Extremely versatile, thanks to the wide range of sizes and materials in which they can be crafted, the Zefiro coffee and side tables can confidently and stylishly furnish any setting.

The tapered cast-aluminum legs, available in satin, chrome, burnished, black chrome or champagne finish, or painted black or white, lend an air of lightness and dynamism to the table.

The tops come in round, square or rectangular shape in a number of different sizes and can be crafted in versions with Canaletto walnut or ash veneer, stained in a number of shades; in glossy lacquer finish, in an array of sophisticated shades; or in various types of luxurious marble.



TIPOLOGIE TAVOLI - TAVOLINI/CONSOLLE **PRODOTTO** TAVOLINO **STRUTTURA** IN METALLO ED ALLUMINIO PRESSOFUSO NELLE FINITURE SATINATO, CROMATO, CROMO NERO, BRUNITO, CHAMPAGNE, BIANCO 100, NERO 900. APPOGGIO A TERRA SU PUNTALI IN MATERIALE TERMOPLASTICO **PIANO** IN LEGNO MASSELLO DI NOCE CANALETTO NELLE FINITURE NATURALE, TINTO EXTRA, TINTO CAFFÈ O IMPIALLACCIATO DI FRASSINO NELLE FINITURE NATURALE, TINTO NOCE, TINTO CILIEGIO, TINTO TEAK, TINTO CAFFÈ, TINTO WENGÉ, TINTO EBANO, TINTO MARRONE O IN LEGNO LACCATO LUCIDO NEI COLORI BIANCO, NERO, LILLA, GRIGIO VERDE, MOKA, SALMONE, TORTORA, VERDE PINO O IN MARMO NELLE TIPOLOGIE CALACATTA ORO LUCIDO, MARMO CALACATTA ORO OPACO, BIANCO CARRARA LUCIDO, NERO MARQUINIA LUCIDO, EMPERADOR LUCIDO, EMPERADOR OPACO

CATEGORIES TABLES - COFFEE TABLES/SIDE TABLES/CONSOLES **PRODUCT** COFFEE TABLE/SIDE TABLE **STRUCTURE** IN METAL AND CAST ALUMINUM WITH SATIN, CHROME, BLACK CHROME, BURNISHED, CHAMPAGNE, WHITE 100 OR BLACK 900 FINISH. RESTS ON PADS MADE OF THERMOPLASTIC MATERIAL **TOP** IN SOLID CANALETTO WALNUT WITH NATURAL FINISH, OR STAINED CANALETTO WALNUT EXTRA OR COFFEE; OR, IN ASH VENEER WITH NATURAL FINISH OR STAINED WALNUT, CHERRY, TEAK, COFFEE, WENGE, EBONY OR BROWN; OR, IN WOOD WITH GLOSSY LACQUER FINISH IN WHITE, BLACK, LILAC, GREY-GREEN, MOCHA, SALMON, DOVE GREY OR PINE GREEN; OR, IN THE FOLLOWING TYPES OF MARBLE: CALACATTA GOLD POLISHED OR MATTE, POLISHED WHITE CARRARA, POLISHED BLACK MARQUINA, EMPERADOR POLISHED OR MATTE



23870

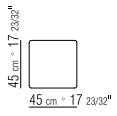

23871

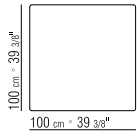
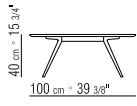

23874

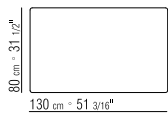
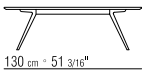
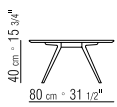

23875

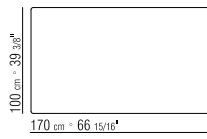
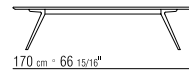
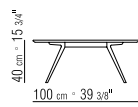

23877



23878

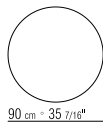
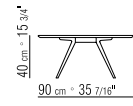

23879

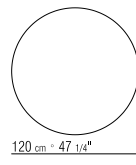
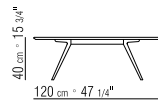

Librerie Contenitori Complementi

Bookshelves | Cabinets | Accessories

| | |
|-------------|-----|
| BOX | 252 |
| FLY | 254 |
| GROUNDPIECE | 258 |
| INFINITY | 260 |
| JEREMY | 268 |
| LIGHTPIECE | 276 |
| MOKA | 280 |
| PIUMA | 284 |
| TAYLOR | 294 |



BOX

Antonio Citterio 2004

Box è un contenitore in cuoio, disponibile in quattro misure.

Progettato quale ideale accessorio della libreria Infinity, Box può essere utilizzato anche da solo come portariviste o portaoggetti da affiancare a divani e poltrone.

Un complemento bello e pratico che trova nel cuoio – materiale caldo e naturale, particolarmente congeniale a Flexform – la sua scelta d'elezione.

Due essenziali fessure ritagliate nei lati del contenitore Box fungono da maniglie e consentono di spostarlo agevolmente.

Box is a cowhide storage basket, available in four sizes.

Designed as the ideal accessory for the Infinity bookcase, Box can also be used by itself as a magazine holder or placed alongside a sofa or armchair as a container for all kinds of objects.

It is an attractive and functional accessory made of warm, natural cowhide – a preferred Flexform material.

Two simple openings cut out of the sides of the Box act as handles to easily pick it up and move it.



**BOOKSHELVES
CABINETS
ACCESSORIES**



TIPOLOGIE LIBRERIE/CONTENITORI/COMPLEMENTI **PRODOTTO** SCATOLA
CONTENITORE **STRUTTURA** IN CUOIO NEI COLORI BIANCO 5007, GRIGIO 5003,
TESTA DI MORO 5004, TESTA DI MORO SCURO 5013, NERO 5005, OLIVA 5006, ROSSO
BULGARO 5008, SABBIA 5001, TABACCO 5015

CATEGORIES BOOKSHELVES/CABINETS/ACCESSORIES **PRODUCT** BOX STRUCTURE
IN COWHIDE IN THE FOLLOWING COLORS: WHITE 5007, GREY 5003, DARK BROWN
5004, EXTRA DARK BROWN 5013, BLACK 5005, OLIVE 5006, BULGARIAN RED 5008,
SAND 5001, TOBACCO 5015

12E30

12E34

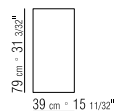
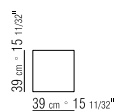
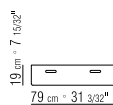
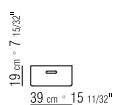

12E31

12E35

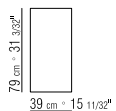
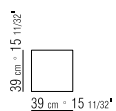
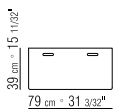
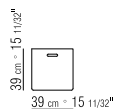

BOX

Data Sheet

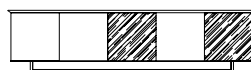

**BOOKSHELVES
CABINETS
ACCESSORIES**

L'ampia famiglia Fly, oltre a numerosi tavoli da pranzo e tavolini, comprende anche due contenitori bassi pensati per un'ideale collocazione nella zona giorno.

Leggeri alla vista, i contenitori Fly sono caratterizzati da una rigorosa struttura in metallo smaltata sia esternamente che internamente con polveri epossidiche in un'ampia gamma di raffinate nuance. I piedi, anch'essi in metallo, presentano il medesimo disegno di quelli utilizzati per i tavoli mentre i piani sono proposti in diverse varietà di marmo.

I contenitori Fly possono essere completati con le ceste in cuoio, disponibili in diversi colori.

The extensive Fly family, in addition to numerous dining tables, coffee and side tables, also includes two low consoles designed for the living room.

Light and airy in appearance, the Fly consoles feature an epoxy-powder-coated metal structure enameled inside and out in a broad range of sophisticated shades. The feet, also made of metal, have the same design as those used for the tables, while the tops come in various types of marble.

The Fly consoles are the perfect place to display the cowhide baskets, available in several colors.



TIPOLOGIE TAVOLI - TAVOLINI/CONSOLLE LIBRERIE/CONTENITORI/COMPLEMENTI
PRODOTTO MOBILE CONTENITORE **STRUTTURA** IN METALLO INTERNAMENTE ED
 ESTERNAMENTE VERNICIATO CON POLVERI EPOSSIDICHE NEI COLORI BIANCO
 100, BEIGE PERLATO 130, BIANCO CREMA 150, BIANCO OPACO 160, PANNA 205,
 ROSSO VINO 405, VERDE KAKI 705, GRIGIO OMBRA 720, GRIGIO TOPO PERLATO 740,
 MARRONE GRIGIO 805, NERO 900 **TOP** IN MARMO NELLE TIPOLOGIE CALACATTA
 ORO LUCIDO, MARMO CALACATTA ORO OPACO, BIANCO CARRARA LUCIDO, NERO
 MARQUINIA LUCIDO, EMPERADOR LUCIDO, EMPERADOR OPACO **SCATOLE** IN
 CUIOIO NEI COLORI BIANCO 5007, GRIGIO 5003, TESTA DI MORO 5004, TESTA DI
 MORO SCURO 5013, NERO 5005, OLIVA 5006, ROSSO BULGARO 5008, SABBIA 5001,
 TABACCO 5015 **PIEDE** IN METALLO NELLE FINITURE SATINATO, CROMATO, CROMO
 NERO, BRUNITO, CHAMPAGNE. APPOGGIO A TERRA SU PUNTALI IN MATERIALE
 TERMOPLASTICO

CATEGORIES TABLES - SMALL TABLES/CONSOLES - BOOKSHELVES/CABINETS/
 ACCESSORIES **PRODUCT** CABINET/BOX THE FOLLOWING COLORS: WHITE 100,
 PEARL BEIGE 130, CREAM-WHITE 150, MATTE WHITE 160, CREAM 205, WINE RED
 405, KHAKI GREEN 705, UMBRA GREY 720, PEARL MOUSE GREY 740, GREY BROWN
 805, BLACK 900 **TOP** IN THE FOLLOWING TYPES OF MARBLE: CALACATTA GOLD
 POLISHED OR MATTE, POLISHED WHITE CARRARA, POLISHED BLACK MARQUINA,
 EMPERADOR POLISHED OR MATTE **BOXES** IN COWHIDE IN THE FOLLOWING
 COLORS: WHITE 5007, GREY 5003, DARK BROWN 5004, EXTRA DARK BROWN 5013,
 BLACK 5005, OLIVE 5006, BULGARIAN RED 5008, SAND 5001, TOBACCO 5015 **FEET**
 IN METAL WITH SATIN, CHROME, BLACK CHROME, BURNISHED OR CHAMPAGNE
 FINISH. RESTS ON PADS MADE OF THERMOPLASTIC MATERIAL



14X80

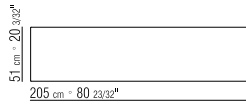

14X81

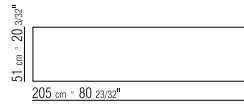
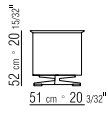

14X30

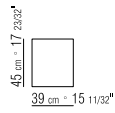
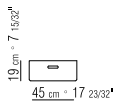

14X31

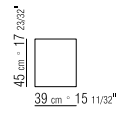
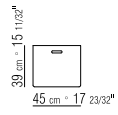

**BOOKSHELVES
CABINETS
ACCESSORIES**



Nata come naturale estensione del sistema di sedute Groundpiece, l'omonima libreria presenta in realtà una sua spiccata personalità che le consente a buon diritto di vivere di vita propria. L'essenziale struttura è realizzata in metallo ed è interamente rivestita in cuoio, in tutti i colori della gamma Flexform; i piedi caratterizzati dal medesimo disegno di quelli del divano sono in metallo verniciato a polvere epossidica.

Da sola o appaiata, la libreria Groundpiece è un mobile dal carattere essenziale ma ricercato che si inserisce armoniosamente in qualsiasi ambiente – di gusto più classico o minimale – sia in contesti residenziali che in uffici direzionali o boutiques.

Created as a natural extension of the Groundpiece seating system, the eponymous bookcase has a striking personality that gives it every right to shine in its own light. The understated structure is made of metal entirely clad in cowhide and comes in all the colors in the Flexform palette; the epoxy-powder-coated metal feet are based on the same design as those on the sofa.

Whether alone or paired, the Groundpiece bookcase is an example of the kind of elegant restraint that makes a style statement in any setting – classic or minimal – whether in residential projects, corporate offices or boutiques.



TIPOLOGIE DIVANI/DIVANI componibili/ POUF - TAVOLINI/CONSOLLE - LIBRERIE/CONTENITORI/COMPLEMENTI - LETTI **PRODOTTO** LIBRERIA CONTENITORE **STRUTTURA** IN METALLO RIVESTITA IN CUIOIO NEI COLORI BIANCO 5007, GRIGIO 5003, TESTA DI MORO 5004, TESTA DI MORO SCURO 5013, NERO 5005, OLIVA 5006, ROSSO BULGARO 5008, SABBIA 5001, TABACCO 5015, SCAMOSCIATO MORO 6004, SCAMOSCIATO NERO 6005, SCAMOSCIATO OLIVA 6003, SCAMOSCIATO SABBIA 6001 **PIEDI** IN METALLO VERNICIATO A FORNO CON POLVERI EPOSSIDICHE. APPOGGIO A TERRA SU PUNTALI IN MATERIALE TERMOPLASTICO

CATEGORIES SOFAS/SECTIONAL SOFAS/OTTOMANS - COFFEE TABLE/SIDE TABLES/CONSOLES - BOOKSHELVES/CABINETS/ACCESSORIES - BEDS **PRODUCT** BOOKSHELF **STRUCTURE** IN METAL UPHOLSTERED IN COWHIDE IN THE FOLLOWING COLORS: WHITE 5007, GREY 5003, DARK BROWN 5004, EXTRA DARK BROWN 5013, BLACK 5005, OLIVE 5006, BULGARIAN RED 5008, SAND 5001 OR TOBACCO 5015; OR, IN SUEDE: DARK BROWN 6004, BLACK 6005, OLIVE 6003 OR SAND 6001 **FEET** IN EPOXY POWDER-COATED METAL. RESTS ON PADS MADE OF THERMOPLASTIC MATERIAL

11M85

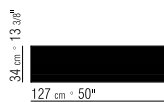
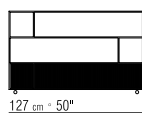
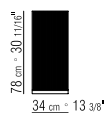

Groundpiece Data Sheet

Infinity

Antonio Citterio 2004

260

**BOOKSHELVES
CABINETS
ACCESSORIES**



Il concept progettuale della libreria Infinity risiede nella sottrazione, nell'idea di annullare il contenitore per valorizzarne il contenuto.

Infinity è un sistema costituito da moduli in metallo smaltato con polveri epossidiche in un'ampia gamma cromatica, liberamente sovrapponibili e uniti tra loro da un'invisibile vite di congiunzione in acciaio satinato.

I moduli del sistema Infinity consentono di realizzare un numero pressoché infinito di composizioni e danno vita ad un elegante gioco di pieni e vuoti.

La libreria Infinity può essere corredata dai pratici quanto raffinati contenitori portaoggetti Box, realizzati in cuoio e dotati di fessure che consentono di sfilarli dalla libreria con grande facilità.

La raffinata combinazione materica tra il rigore della lamiera metallica ed il calore del cuoio sono all'origine del successo di un prodotto ormai considerato a buon diritto iconico.

The design concept for the Infinity bookcase lies in subtraction – the concept of paring down the container in order to allow the contents to shine.

Infinity is a modular system made of epoxy-powder-coated metal containers that come in an extensive array of colors, freely stackable and joined to each other by an invisible satin-finish steel connector screw.

The Infinity system modules make it possible to create an almost infinite number of compositions, giving rise to an elegant interplay of negative and positive spaces.

The Infinity bookcase can be paired with the practical yet refined cowhide Box containers with side slit handles for easy removal from the bookcase.

The sophisticated textural contrast between the understated sheet metal and the warmth of the cowhide is the source of success for a product that can now be justifiably considered iconic.

FRANCE | ALSACE | "5 TERRES HOTEL & SPA" | BOX | INFINITY BOOKSHELF | GROUNDPIECE SOFA | THOMAS ARMCHAIRS | TRIS COFFEE TABLE







TIPOLOGIE TAVOLINI/CONSOLLE - LIBRERIE/CONTENITORI/COMPLEMENTI **PRODOTTO** LIBRERIA **STRUTTURA** IN METALLO INTERNAMENTE ED ESTERNAMENTE VERNICIATA A FORNO CON POLVERI EPOSSIDICHE NEI COLORI BIANCO 100, BEIGE PERLATO 130, BIANCO CREMA 150, BIANCO OPACO 160, PANNA 205, ROSSO VINO 405, VERDE KAKI 705, GRIGIO OMBRA 720, GRIGIO TOPO PERLATO 740, MARRONE GRIGIO 805, NERO 900 **TOP** IN METALLO VERNICIATO A FORNO CON POLVERI EPOSSIDICHE E CRISTALLO RETROVERNICIATO NEI COLORI BIANCO 100, BEIGE PERLATO 130, BIANCO CREMA 150, BIANCO OPACO 160, PANNA 205, ROSSO VINO 405, VERDE KAKI 705, GRIGIO OMBRA 720, GRIGIO TOPO PERLATO 740, MARRONE GRIGIO 805, NERO 900 **CONGIUNZIONI** IN ACCIAIO SATINATO **BASAMENTO** IN METALLO CROMATO

CATEGORIES COFFEE TABLES/SIDE TABLES/CONSOLES - BOOKSHELVES/CABINETS/ACCESSORIES **PRODUCT** BOOKSHELF **STRUCTURE** IN EPOXY-POWDER-COATED METAL, ENAMELED INSIDE AND OUT IN THE FOLLOWING COLORS: WHITE 100, PEARL BEIGE 130, CREAM-WHITE 150, MATTE WHITE 160, CREAM 205, WINE RED 405, KHAKI GREEN 705, UMBRA GREY 720, PEARL MOUSE GREY 740, GREY BROWN 805, BLACK 900 **TOP** IN EPOXY-POWDER-COATED METAL AND BACKPAINTED GLASS, ENAMELED IN THE FOLLOWING COLORS: WHITE 100, PEARL BEIGE 130, CREAM-WHITE 150, MATTE WHITE 160, CREAM 205, WINE RED 405, KHAKI GREEN 705, UMBRA GREY 720, PEARL MOUSE GREY 740, GREY BROWN 805, BLACK 900 **CONNECTORS** IN SATIN-FINISH STEEL **BASE** IN METAL WITH CHROME FINISH



12D40
BASE

12D42
BASE

12D44
BASE

12D45
BASE

12D46
BASE

1.5 cm = 0.1932"

40 cm = 15 3/4"

40 cm = 15 3/4"

80 cm = 31 1/2"

120 cm = 47 1/4"

160 cm = 62 15/16"

200 cm = 78 3/4"

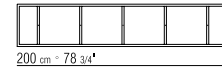
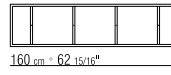
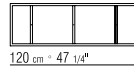
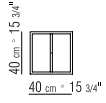

12D50
BASE

12D51
BASE

12D52
BASE

12D53
BASE

12D54
BASE

1.5 cm = 0.1932"

80 cm = 31 1/2"

80 cm = 31 1/2"

120 cm = 47 1/4"

160 cm = 63"

200 cm = 78 3/4"

1.5 cm = 0.1932"

120 cm = 47 1/4"

120 cm = 47 1/4"

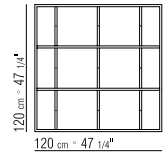
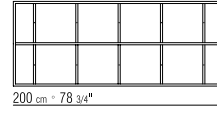
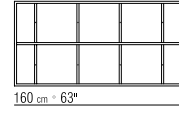
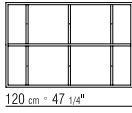
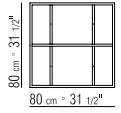

12D26
MODULO / UNIT

12D20
MODULO / UNIT

12D21
MODULO / UNIT

0.3 cm = 0.118"

40 cm = 15 3/4"

40 cm = 15 3/4"

20 cm = 7.87"

40 cm = 15 3/4"

40 cm = 15 3/4"

20 cm = 7.87"

80 cm = 31 1/2"

40 cm = 15 3/4"

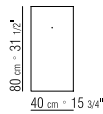
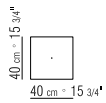

12D22
MODULO / UNIT

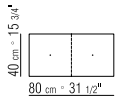
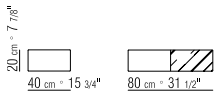

12D23
MODULO / UNIT

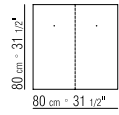
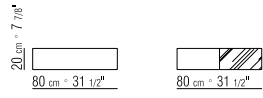

12D24
MODULO / UNIT

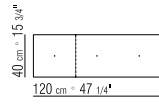
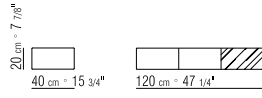

12D30
MODULO / UNIT

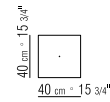
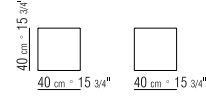

12D31
MODULO / UNIT

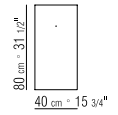
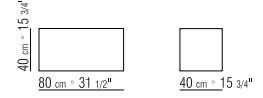

12D32
MODULO / UNIT

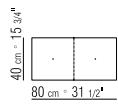
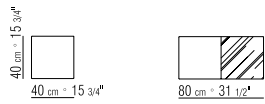

12D33
MODULO / UNIT

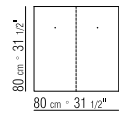
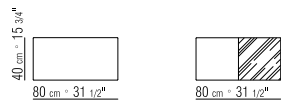

12D34
MODULO / UNIT

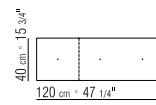
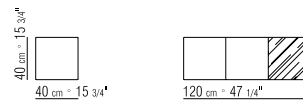

12D74
TOP

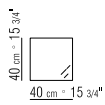
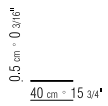

12D55
TOP



12D56
TOP

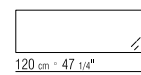
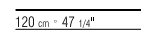

12D58
TOP

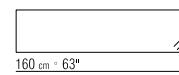
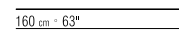

12D60
TOP

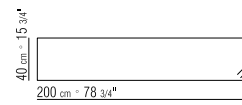
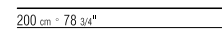

12D64
TOP

12D66
TOP

12D68
TOP

12D70
TOP

12D76
TOP

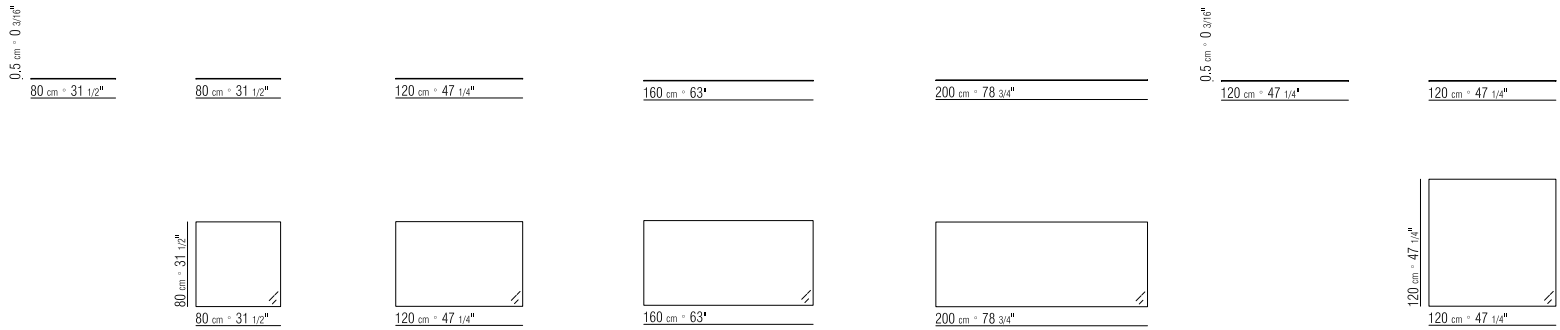

COMPOSIZIONI / COMPOSITIONS

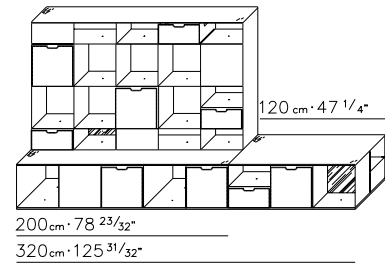
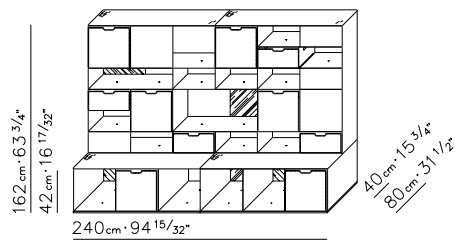
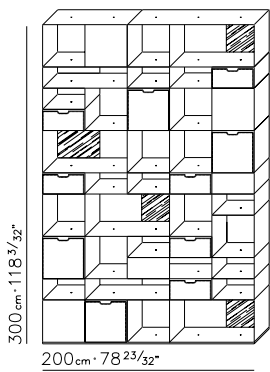
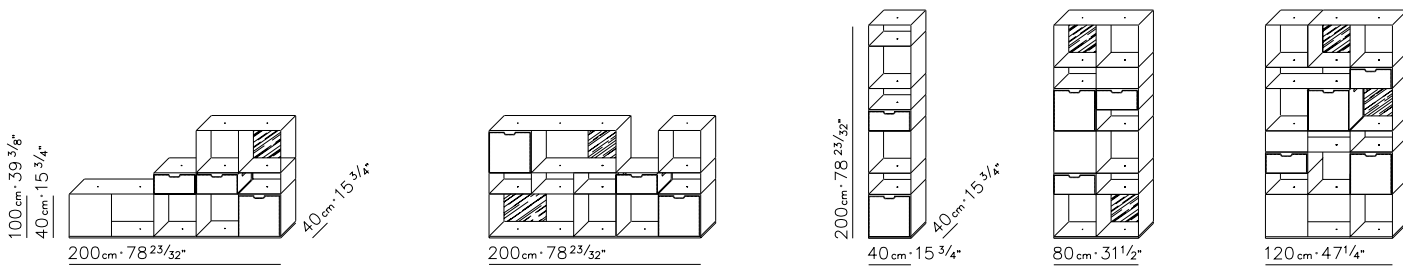

Jeremy

Carlo Colombo 2019

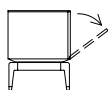

BOOKSHELVES CABINETS ACCESSORIES

Mostrare o celare, è a questa dicotomia che si ispira il concept della famiglia di contenitori Jeremy caratterizzati da linee estetiche pure e da volumi essenziali che sviluppano un'armoniosa alternanza di pieni e vuoti, di vani a giorno pensati per esporre oggetti di pregio e di elementi chiusi da ante a ribalta.

Di particolare interesse la contrapposizione tra la leggerezza delle teche realizzate in vetro fumè e la ruvida matericità del rovere cotto. I contenitori Jeremy sono realizzati anche nella versione laccata lucida nei colori bianco, tortora, e nero e poggiano su raffinati piedi in alluminio pressofuso disponibili nelle finiture brunito e satinato.

La famiglia di contenitori Jeremy comprende configurazioni con ante a ribalta e cassetti, variamente attrezzate, ciascuna delle quali pensata per differenti collocazioni all'interno dello spazio domestico: dall'ingresso fino al living. Tutti gli elementi sono finiti anche nella parte posteriore e possono essere pertanto utilizzati anche per suddividere gli spazi.

To reveal or conceal is the question that inspired the aesthetic of the Jeremy family of cabinets. Distinguished by pure lines and sleek proportions that build upon a rhythmic alternation of negative and positive spaces, it offers a series of revealing open compartments to display treasured objects, and concealing closed compartments with drop-front doors.

Especially fascinating is the contrast between the lightness of the smoked glass compartments and the textured surface of the cooked oak. The Jeremy cabinets are also available in glossy lacquer finish in three colors: white, dove grey or black; and rest on elegant cast aluminum feet with burnished or satin finish.

The Jeremy family includes compositions with drawers and drop-front doors, with various fittings, each of which is designed to be placed in different parts of the home, from the entry to the living room. All of the elements are finished on the back, making them suitable as room dividers.



270







ITALY | ARONA | PRIVATE VILLA | JEREMY SIDEBOARD | SVEVA SOFA | ZEFIRO SIDE TABLE



274

Data Sheet

Jeremy

TIPOLOGIE LIBRERIE/COMPLEMENTI/CONTENITORI **PRODOTTO** CONTENITORE **MODULI** IN LEGNO IMPIALLACCIATO DI ROVERE TERMOTRATTATO O IN LEGNO LACCATO LUCIDO NELLE FINITURE BIANCO, NERO, TORTORA. MODULI DISPONIBILI ANCHE IN VETRO O IN VETRO CON CASSETTI IN LEGNO COORDINATO CON ELEMENTO DA 140 **RIPIANI** IN VETRO **BASE** IN METALLO VERNICIATO A FORNO CON POLVERI EPOSSIDICHE **PIEDI** IN ALLUMINIO PRESSOFUSO NELLE FINITURE SATINATO O BRUNITO CON PUNTALI IN CONTRASTO. APPOGGIO A TERRA SU PUNTALI IN MATERIALE TERMOPLASTICO

CATEGORIES BOOKCASES/ACCESSORIES/CABINETS **PRODUCT** CABINET **MODULES** IN HEAT-TREATED OAK VENEER OR IN WOOD WITH GLOSSY LACQUER FINISH IN WHITE, BLACK, DOVE GREY. MODULES ALSO AVAILABLE IN GLASS OR IN GLASS WITH WOOD DRAWERS COORDINATED WITH THE 140 CM ELEMENT **SHELVES** IN GLASS **BASE** IN EPOXY POWDER-COATED METAL **FEET** IN CAST ALUMINUM WITH SATIN OR BURNISHED FINISH AND CONTRASTING TIPS. RESTS ON PADS MADE OF THERMOPLASTIC MATERIAL



25460

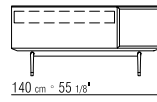
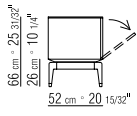

25462

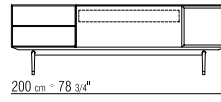

25463

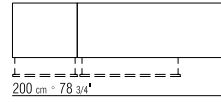
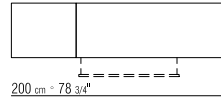
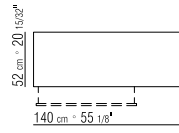
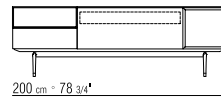

25468

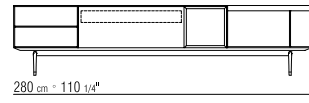
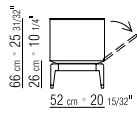

25469

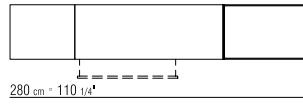
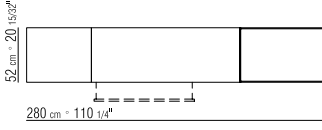
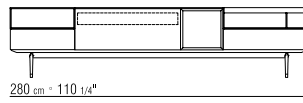

25470

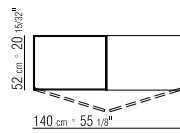
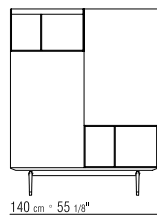
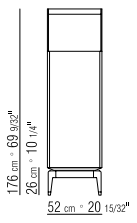

Lightpiece

Antonio Citterio 2008

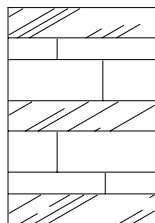

**BOOKSHELVES
CABINETS
ACCESSORIES**

La libreria Lightpiece è assolutamente complementare all'omonimo sistema di seduta e presenta il medesimo carattere rigoroso e leggero, che le consentono di inserirsi armoniosamente in qualsiasi ambiente. La struttura è realizzata in metallo e prevede la combinazione di due finiture: quella esterna è in acciaio lucido mentre quella interna è in metallo smaltato a polvere epossidica in un'ampia gamma cromatica. Prodotta in un'unica altezza – 184 cm – la libreria Lightpiece è disponibile in tre larghezze; i moduli possono essere utilizzati da soli o accostati tra loro a comporre una libreria di più ampie dimensioni.

Having inherited the light uncluttered good looks of its namesake seating system, the Lightpiece bookcase is perfectly complementary to any of the pieces, making it an effortless fit in any setting.

The metal structure comes with a combination of two finishes – external finish in polished steel with interior in epoxy-powder-coated metal – available in an extensive color palette.

Manufactured in just one height – 184 cm – the Lightpiece bookcase comes in three widths; the modules can stand alone or be paired to form a larger bookcase unit.



278



TIPOLOGIE DIVANI/DIVANI COMPONENTI/POUF - LIBRERIE/CONTENITORI/COMPLEMENTI
PRODOTTO LIBRERIA **STRUTTURA** IN METALLO, INTERNAMENTE VERNICIATA CON
 POLVERI EPOSSIDICHE NEI COLORI BIANCO 100, BEIGE PERLATO 130, BIANCO
 CREMA 150, BIANCO OPACO 160, PANNA 205, ROSSO VINO 405, VERDE KAKI 705,
 GRIGIO OMBRA 720, GRIGIO TOPO PERLATO 740, MARRONE GRIGIO 805, NERO
 900. **FINITURA ESTERNA** IN ACCIAIO LUCIDO

CATEGORIES SOFAS/SECTIONAL SOFAS/OTTOMANS - BOOKSHELVES/CABINETS/
 ACCESSORIES **PRODUCT** BOOKSHELF **STRUCTURE** IN EPOXY-POWDER-COATED
 METAL, ENAMELED INSIDE IN THE FOLLOWING COLORS: WHITE 100, PEARL BEIGE
 130, CREAM-WHITE 150, MATTE WHITE 160, CREAM 205, WINE RED 405, KHAKI
 GREEN 705, UMBRA GREY 720, PEARL MOUSE GREY 740, GREY BROWN 805,
 BLACK 900. **OUTSIDE FINISHED** IN POLISHED STEEL

11P80

11P81

11P82

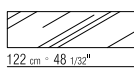
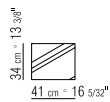
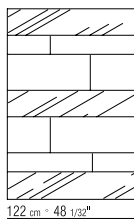
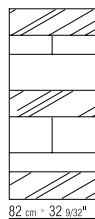
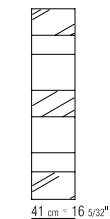
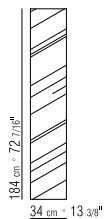

Lightpiece

Data Sheet

**BOOKSHELVES
CABINETS
ACCESSORIES**

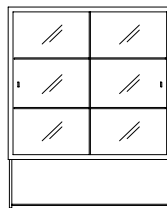

La vetrina Moka appartiene all'omonima collezione progettata da Mario Asnago e Claudio Vender nel 1939 e prodotta da Flexform dal 1985.

La vetrina Moka è ricca di riferimenti progettuali che rimandando al razionalismo, corrente artistica ed architettonica che vede tra i maggiori esponenti proprio Mario Asnago e Claudio Vender, che hanno iniziato il loro sodalizio professionale negli anni Trenta.

La struttura della vetrina è costituita da una raffinata cornice in noce canaletto o frassino, tinti in una pluralità di finiture. La vetrina poggia su un esile quanto elegante tubolare metallico disponibile nelle finiture verniciato alluminio, bianco e nero che va a formare un ricercato disegno a crociera nella parte di appoggio al pavimento.

Ante, schienale e ripiani sono in vetro e conferiscono alla vetrina Moka un carattere leggero ed essenziale, che la rendono sorprendentemente moderna ed attuale.

The Moka display case is part of the eponymous collection designed by Mario Asnago and Claudio Vender in 1939 and produced by Flexform since 1985.

The Moka display case is filled with design references that trace back to Rationalism, an artistic and architectural movement of which the two architects, Asnago and Vender, who formed their professional partnership in the 1930s, were among the greatest exponents.

Framed in Canaletto walnut or ash, available in a number of stain finishes, the display case sits on a slender, elegant tubular metal structure that is available in black or white painted aluminum. The structure forms a sophisticated X-shaped design at the base.

The doors, back panel and shelves are all made of glass and lend the Moka display case a light, minimalist look with a surprisingly modern feel that is entirely relevant today.



TIPOLOGIE POLTRONCINE/SEDIE/SGABELLI - TAVOLI - LIBRERIE/CONTENITORI/
COMPLEMENTI **PRODOTTO** VETRINA **STRUTTURA** IN LEGNO IMPIALLACCIATO
DI NOCE CANALETTO NELLE FINITURE NATURALE, TINTO EXTRA, TINTO CAFFÈ O
IMPIALLACCIATO DI FRASSINO NELLE FINITURE NATURALE, TINTO NOCE, TINTO
CILIEGIO, TINTO TEAK, TINTO CAFFÈ, TINTO WENGÉ, TINTO EBANO, TINTO MARRONE
GAMBE IN METALLO VERNICIATO CON POLVERI EPOSSIDICHE NEI COLORI BIANCO,
NERO, ALLUMINIO. APPOGGIO A TERRA SU PUNTALI IN MATERIALE TERMOPLASTICO
ANTE SCORREVOLI IN VETRO TRASPARENTE **SCHIENALE** IN VETRO TRASPARENTE
RIPIANI IN VETRO TRASPARENTE

CATEGORIES SMALL ARMCHAIRS/CHAIRS/STOOLS - TABLES - BOOKSHELVES/
CABINETS/ACCESSORIES **PRODUCT** BOOKSHELF **STRUCTURE** IN CANALETTO
WALNUT VENEER WITH NATURAL FINISH, OR STAINED CANALETTO WALNUT EXTRA
OR COFFEE; OR, IN ASH VENEER WITH NATURAL FINISH OR STAINED WALNUT,
CHERRY, TEAK, COFFEE, WENGE, EBONY OR BROWN **LEGS** IN EPOXY POWDER-
COATED METAL IN WHITE, BLACK OR ALUMINUM COLOR. RESTS ON PADS MADE
OF THERMOPLASTIC MATERIAL **SLIDING DOORS** IN TRANSPARENT GLASS **BACK** IN
TRANSPARENT GLASS **SHELVES** IN TRANSPARENT GLASS

14575

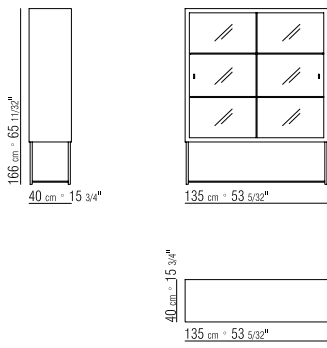

**BOOKSHELVES
CABINETS
ACCESSORIES**

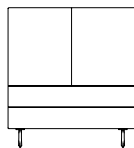

La collezione di contenitori Piuma coniuga il rigore della forma con la ricca espressività del legno.

Alla studiata semplicità del disegno fa da contrappunto la scelta dell'impiallacciatura realizzata con essenze rare e pregiate come la piuma di mogano, l'ebano amara, il noce canaletto ed il frassino proposti in una varietà di nuance.

L'assenza di maniglie, ricavate direttamente nella struttura con presa a gola e il taglio a 45° accentua la linea asciutta ed essenziale di questi mobili che si prestano ad essere inseriti in qualunque ambiente e sono di facile abbinamento con tutti i tavoli, le sedie, i divani e le poltrone della collezione Flexform.

I contenitori Piuma sono proposti in numerose configurazioni sia a sviluppo verticale che orizzontale: credenze con ante e cassetti, madie, elementi porta-tv e tavolini con cassetti.

Tutti gli elementi si presentano perfettamente finiti anche nella parte posteriore e si prestano pertanto anche ad essere collocati al centro dell'ambiente.

The Piuma collection of cabinets is a delightful marriage of understated elegance-of-form and the dramatic expressiveness of wood.

In contrast to the deliberate simplicity of the design is the choice of veneers – crafted with exotic, rare woods like mahogany featherband, Amara ebony, Canaletto walnut and ash, available in a number of shades.

Free of handles, the finger pull is cut directly into the structure. A 45° mitered edge on the door/drawer serves as a finger grip, accentuating the clean, smooth lines of these cabinets that can be included in any setting and easily paired with all the tables, chairs, sofas and armchairs in the Flexform collection.

Piuma cabinets are available in many configurations, both vertical and horizontal – credenzas with doors and drawers, hutches and sideboards, TV entertainment centers and coffee tables with drawers. Flawlessly finished, even on the back, these pieces also make a stunning statement when placed in the center of a room.



286





288





290

A nightstand showing a striking combination of deliberately simple design and the sheer expressiveness of wood.





TIPOLOGIE LIBRERIE/CONTENITORI/COMPLEMENTI **PRODOTTO** CONTENITORE **STRUTTURA** IN LEGNO IMPIALLACCIATO DI PIUMA DI MOGANO O DI NOCE CANALETTO NELLE FINITURE NATURALE, TINTO EXTRA, TINTO CAFFÈ O IMPIALLACCIATO DI FRASSINO NELLE FINITURE NATURALE, TINTO NOCE, TINTO CILIEGIO, TINTO TEAK, TINTO CAFFÈ, TINTO WENGÉ, TINTO EBANO, TINTO MARRONE O IMPIALLACCIATO DI EBANO AMARA. PER LA VERSIONE IN PIUMA DI MOGANO L'INTERNO È SOLO IN ACERO NATURALE. COD. 20782 - 20783 - 20784 NON DISPONIBILI IN PIUMA DI MOGANO **RIPIANI** IN VETRO TRASPARENTE **PIEDI** IN METALLO NELLE FINITURE SATINATO, CROMATO, CROMO NERO, BRUNITO, CHAMPAGNE. APPOGGIO A TERRA SU PUNTALI IN MATERIALE TERMOPLASTICO

PRODOTTO COMODINO (COD. 20770-20771) **STRUTTURA** IN LEGNO IMPIALLACCIATO DI NOCE CANALETTO NELLE FINITURE NATURALE, TINTO EXTRA, TINTO CAFFÈ O IMPIALLACCIATO DI FRASSINO NELLE FINITURE NATURALE, TINTO NOCE, TINTO CILIEGIO, TINTO TEAK, TINTO CAFFÈ, TINTO WENGÉ, TINTO EBANO, TINTO MARRONE O DI EBANO AMARA **PIEDI** IN ALLUMINIO PRESSOFUSO NELLE FINITURE SATINATO, CROMATO, CROMO NERO, BRUNITO, CHAMPAGNE. APPOGGIO A TERRA SU PUNTALI IN MATERIALE TERMOPLASTICO

CATEGORIES BOOKSHELVES/CABINETS/ACCESSORIES **PRODUCT** CABINET **STRUCTURE** IN MAHOGANY FEATHERBAND VENEER OR CANALETTO WALNUT VENEER WITH NATURAL FINISH, OR STAINED CANALETTO WALNUT EXTRA OR COFFEE; OR, IN ASH VENEER WITH NATURAL FINISH OR STAINED WALNUT, CHERRY, TEAK, COFFEE, WENGE, EBONY OR BROWN; OR, IN AMARA EBONY VENEER. FOR THE MAHOGANY FEATHERBAND VERSION, THE INTERIOR IS MADE ONLY IN NATURAL MAPLE. COD. 20782 - 20783 - 20784 NOT AVAILABLE IN MAHOGANY FEATHERBAND **SHELVES** IN TRANSPARENT GLASS **FEET** IN METAL WITH SATIN, CHROME, BLACK CHROME, BURNISHED OR CHAMPAGNE FINISH. RESTS ON PADS MADE OF THERMOPLASTIC MATERIAL

PRODUCT BEDSIDE TABLE (COD. 20770-20771) **STRUCTURE** IN CANALETTO WALNUT VENEER WITH NATURAL FINISH, OR STAINED CANALETTO WALNUT EXTRA OR COFFEE; OR, IN ASH VENEER WITH NATURAL FINISH OR STAINED WALNUT, CHERRY, TEAK, COFFEE, WENGE, EBONY OR BROWN; OR IN AMARA EBONY **FEET** IN CAST ALUMINUM WITH SATIN, CHROME, BLACK CHROME, BURNISHED OR CHAMPAGNE FINISH. RESTS ON PADS MADE OF THERMOPLASTIC MATERIAL

20760

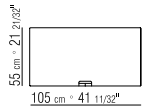
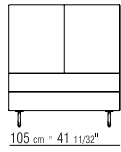
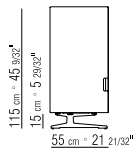

20765

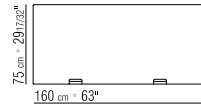
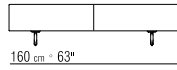
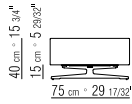

20766

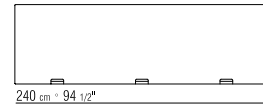
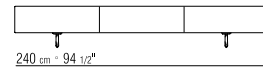

20770

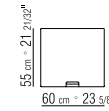
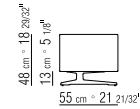

20771

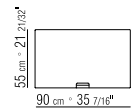
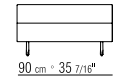

20767

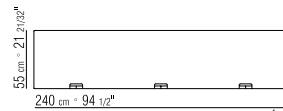
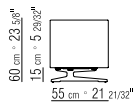

20768

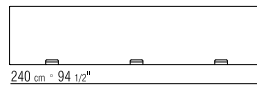
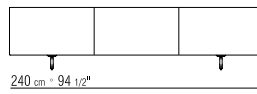

20769

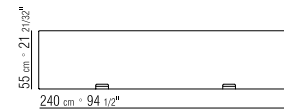
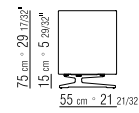

20782

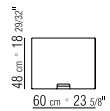
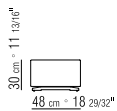

20783

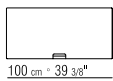
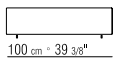

20784

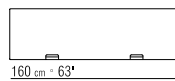
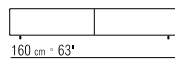

20788

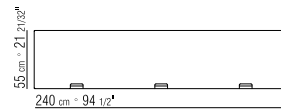
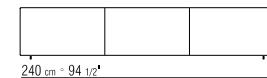
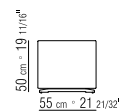

20788

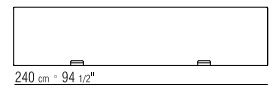
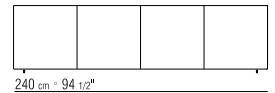
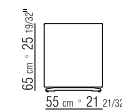

**BOOKSHELVES
CABINETS
ACCESSORIES**

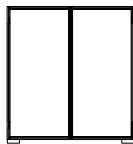

La famiglia di contenitori Taylor, caratterizzata da una linea essenziale e moderna e da ricercati dettagli costruttivi, è proposta in un'ampia gamma di elementi e finiture.

La leggera struttura è in alluminio brunito mentre le ante a battente o scorrevoli possono essere rivestite in cuoio oppure impiallacciate in noce canaletto, frassino ed ebano amara, in una varietà di tinte raffinate. Il piano può essere realizzato anch'esso in essenza per ottenere un effetto di continuità con la facciata oppure in marmo per creare invece un garbato contrasto.

I mobili si mantengono leggermente sollevati da terra tramite piedini in metallo brunito.

I contenitori Taylor sono disponibili in una pluralità di configurazioni differenti sia a sviluppo verticale che orizzontale, che risponde a diverse esigenze di utilizzo e ne moltiplica le possibilità di collocazione all'interno dell'ambiente domestico, dall'ingresso al living, fino alla zona notte.

Tutti gli elementi si presentano perfettamente finiti anche nella parte posteriore e si prestano pertanto anche ad essere collocati al centro dell'ambiente.

The Taylor family of cabinets, with their sleek, modern lines and sophisticated construction details, comes in an extensive array of elements and finishes.

The lightweight structure is in burnished aluminum while the hinged or sliding doors can be clad in cowhide, or in Canaletto walnut, ash or Amara ebony veneers, in a palette of elegant colors.

The top can also be crafted in wood, for seamless continuity with the front, or in marble, to create a delicate contrast.

The cabinets are raised just off the floor on burnished metal feet.

Taylor cabinets are available in a number of different vertical or horizontal configurations to satisfy various decor needs, multiplying the possibilities of placement in the home – from the entry to the living room and all the way to the bedroom.

All the elements are flawlessly finished, even on the back, for elegant placement in the center of a room.



296



A practical yet elegant sideboard displaying modern lines and sophisticated construction details.







TIPOLOGIE LIBRERIE/CONTENITORI/COMPLEMENTI **PRODOTTO** CONTENITORE
STRUTTURA IN ALLUMINIO ESTRUSO IN COLORE BRUNITO **SCHIENALE E ANTA** A
 BATTENTE O SCORREVOLE IN ALLUMINIO CON PANNELLO IN LEGNO IMPIALLACCIATO
 DI NOCE CANALETTO NELLE FINITURE NATURALE, TINTO EXTRA, TINTO CAFFÈ; O
 IMPIALLACCIATO DI FRASSINO NELLE FINITURE NATURALE, TINTO NOCE, TINTO
 CILIEGIO, TINTO TEAK, TINTO CAFFÈ, TINTO WENGÉ, TINTO EBANO, TINTO MARRONE O
 IN EBANO AMARA; O IN LEGNO RIVESTITO IN CUIOIO NEI COLORI BIANCO 5007, GRIGIO
 5003, TESTA DI MORO 5004, TESTA DI MORO SCURO 5013, NERO 5005, OLIVA 5006,
 ROSSO BULGARO 5008, SABBIA 5001, TABACCO 5015 **CASSETTI** IN ALLUMINIO CON
 FONDO IN VETRO **RIPIANO** IN VETRO TRASPARENTE **TOP** IN MARMO NELLE TIPOLOGIE
 CALACATTA ORO LUCIDO, MARMO CALACATTA ORO OPACO, BIANCO CARRARA
 LUCIDO, NERO MARQUINIA LUCIDO, EMPERADOR LUCIDO, EMPERADOR OPACO O
 IN LEGNO IMPIALLACCIATO DI NOCE CANALETTO NELLE FINITURE NATURALE, TINTO
 EXTRA, TINTO CAFFÈ O IMPIALLACCIATO DI FRASSINO NELLE FINITURE NATURALE,
 TINTO NOCE, TINTO CILIEGIO, TINTO TEAK, TINTO CAFFÈ, TINTO WENGÉ, TINTO
 EBANO, TINTO MARRONE; IN EBANO AMARA. TUTTI I TOP SONO A RICHIESTA E CON
 SUPPLEMENTO DI PREZZO **PIEDI** IN ALLUMINIO PRESSOFUSO IN COLORE BRUNITO

CATEGORIES BOOKSHELVES/CABINETS/ACCESSORIES **PRODUCT** CABINET
STRUCTURE IN BURNISHED COLOR EXTRUDED ALUMINUM **BACK AND HINGED**
 OR SLIDING DOORS IN ALUMINUM WITH PANEL IN CANALETTO WALNUT VENEER
 WITH NATURAL FINISH OR STAINED CANALETTO WALNUT EXTRA OR COFFEE; OR, IN
 ASH VENEER WITH NATURAL FINISH OR STAINED WALNUT, CHERRY, TEAK, COFFEE,
 WENGE, EBONY OR BROWN; OR, IN AMARA EBONY; OR, IN WOOD UPHOLSTERED IN
 COWHIDE IN THE FOLLOWING COLORS: WHITE 5007, GREY 5003, DARK BROWN 5004,
 EXTRA DARK BROWN 5013, BLACK 5005, OLIVE 5006, BULGARIAN RED 5008, SAND
 5001 OR TOBACCO 5015 **DRAWERS** IN ALUMINUM WITH GLASS BOTTOM **SHELF** IN
 TRANSPARENT GLASS **TOP** IN THE FOLLOWING TYPES OF MARBLE: CALACATTA GOLD
 POLISHED OR MATTE, POLISHED WHITE CARRARA, POLISHED BLACK MARQUINA,
 EMPERADOR POLISHED OR MATTE; OR, IN CANALETTO WALNUT VENEER WITH
 NATURAL FINISH, OR STAINED CANALETTO WALNUT EXTRA OR COFFEE; OR, IN
 ASH VENEER WITH NATURAL FINISH OR STAINED WALNUT, CHERRY, TEAK, COFFEE,
 WENGE, EBONY OR BROWN; IN AMARA EBONY. ALL TOP ARE UPON REQUEST AND
 WITH UPCHARGE **FEET** IN BURNISHED COLOR CAST ALUMINUM

24160

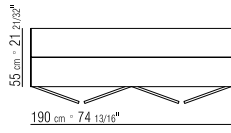
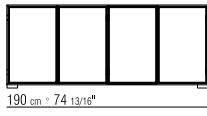
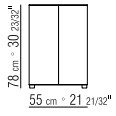
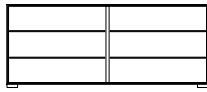

24162

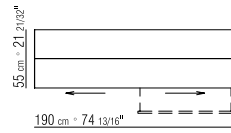
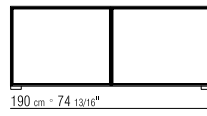
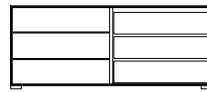

24164

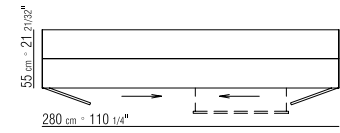
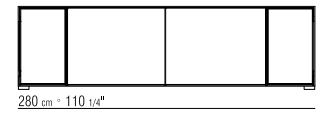
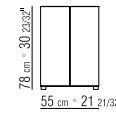
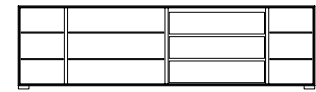

24166

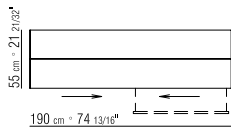
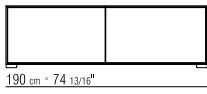
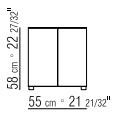

24167

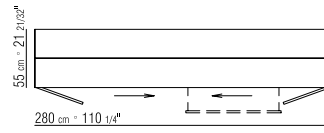
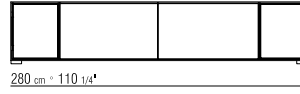
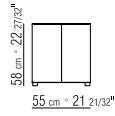
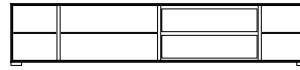

24157

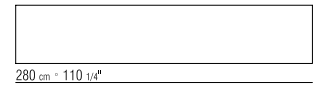
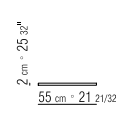

24179

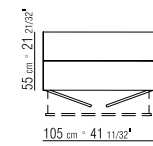
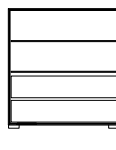
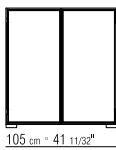
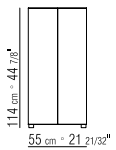

24159

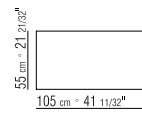
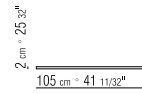
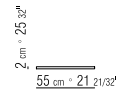

24150

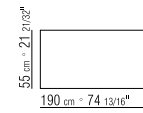
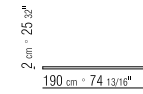
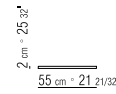

Credits

- 7
ITALY, BERGAMO
PRIVATE PENTHOUSE
PHOTO:
ALESSANDRO BELUSSI
- 13
COURTESY:
STORCHEN ZÜRICH HOTEL
- 17
PROJECT:
STUDIO ELENA VIGANÒ
- 21
PROJECT: STUDIO KATE
PHOTO: MAREE HOMER
PHOTOGRAPHY
- 24
PROJECT:
FLEXFORM SINGAPORE /
STUDIO216
- 26
PROJECT: RR INTERIEUR
PHOTO: CAFEINE
- 43
PROJECT:
MIGDAL ARQUITECTOS,
GRUPO ARQUITECTURA,
PISO 18 CONTRACT
- 44
COURTESY:
PALUMBO SUPERYACHTS
- 61
PROJECT:
NEBIHE CIHAN STUDIO
PHOTO:
MATT HARRINGTON
- 63
PROJECT:
ANTONIO CITTERIO
PATRICIA VIEL
- 71
PROJECT:
DANIEL ALVAREZ
GRUPO ARQUITECTURA
PISO 18 CONTRACT
PHOTO: AGUSTIN GARZA
- 75
PROJECT:
NATALIA OLEKSIENKO
STUDIO "EVOLUTIONARY
ARCHITECTURE"
PHOTO: ANDREY AVDEENKO
- 79
ITALY, MEDA,
VILLA TRAVERSI
- 81
PROJECT:
ARCH. MASSIMO RECCANELLO
MRP ARCHITETTURA
- PHOTO:*
PIETRO SAVORELLI
- 85
COURTESY:
GRAND HOTEL TREMEZZO
- 89
PHOTO:
ALESSANDRO BELUSSI
- 95
PROJECT:
NEBIHE CIHAN STUDIO
PHOTO:
MATT HARRINGTON
- 105
COURTESY:
FLEXFORM TOKYO
- 109
PROJECT:
TERRAZA BALEAR INTERIOR
DESIGN & FURNITURE
- 126
PROJECT:
TERRAZA BALEAR INTERIOR
DESIGN & FURNITURE
- 141
PROJECT:
TERRAZA BALEAR INTERIOR
DESIGN & FURNITURE
- 147
PROJECT:
STILLONE DESIGN
PHOTO: MAREE HOMER
PHOTOGRAPHY
- 155
PROJECT:
STAFFAN TOLLGARD
DESIGN GROUP
PHOTO:
MARY WADSWORTH
- 163
PROJECT:
FISCHER ARCHITECTURE
INTERIOR DESIGN:
MEAD QUIN DESIGN
PHOTO: AUBRI PICK
- 167
PROJECT:
STUDIO WKK
ARCHITECTS UK
INTERIOR ARCHITECT:
ELENA SAVVIDOU /
CASAMIA - SHOWROOM
- 177
COURTESY: HOPROM
- 181
CREDITS:
© SANOMA REGIONAL
BELGIUM N.V./S.A.
- PHOTO:* JOHAN SAMYN -
STIJVOL WONEN
- 185
PROJECT:
KORAY YAVUZER
ARCHITECTURE / MASLAK YAPI
- 189
PROJECT:
INGE VAN POPPEL
INTERIEUR ARCHITECTUUR
PHOTO: TESSA FRANCESCA
- 193
PROJECT: ARCHETONIC
PHOTO:
RAFAEL GAMO
- 194
PROJECT:
MOOD WORKS -
KARINA SNUSZKA
& DOROTA KUĆ.
PHOTO: RAFAL LIPSKI
- 203
PROJECT:
STAFFAN TOLLGARD
DESIGN GROUP
PHOTO:
VASCO CÉLIO
- 209
PROJECT:
TERRAZA BALEAR INTERIOR
DESIGN & FURNITURE
- 213
PROJECT:
BYRON & JONES INTERIORS
- 217
PHOTO:
DIDIER DELMAS
- 221
PROJECT:
FLEXFORM SINGAPORE
STUDIO 216
- 225
PROJECT:
NOVALIS.O.
- 239
PROJECT:
STYLING BEK SHEPPARD
PHOTO:
REUBEN GATES
- 243
PROJECT:
LIGHTHOUSE.PROJECTS
PHOTO: SERGEY ANANIEV
- 251
USA, NEW YORK, PRIVATE
PENTHOUSE
PROJECT:
STUDIO PIET BOON
- 255
PHOTO:
ALESSANDRO BELUSSI
- 261
PROJECT:
LATITUDES ET MÉRIDIDIEN
PHOTO:
SERGE LOHNER
- 285
PHOTO:
DIDIER DELMAS
- 289
PROJECT:
MARE DESIGN CENTER
PHOTO:
ROBERTO D'AMBROSIO
- 291
PROJECT:
FRANKLY AMSTERDAM
PHOTO:
KASIA GATKOWSKA

PRINTED IN ITALY
JULY 2019

FLEXFORM S.P.A.
VIA EINAUDI 23/25
20821 MEDA (MB) ITALIA
TEL. +39 0362 3991
INFO@FLEXFORM.IT
WWW.FLEXFORM.IT



Management
System
ISO 9001:2015



www.tuv.com
ID 9108635793